

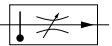





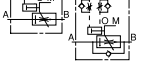

# D

## FLOW CONTROLS

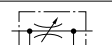
Valve Type	Graphic Symbols	Maximum Operating Pressure MPa (PSI)	Maximum Flow												Page				
			1	5	10	50	100	U.S.GPM		L/min									
			1	2	3	5	10	20	30	50	100	200	300	500	1000	2000	3000	5000	
Flow Control Valves		21 (3050)	FG	01	02	03	06	10											277
Flow Control and Check Valves		21 (3050)	FCG	01	02	03	06	10											277
Pilot Operated Flow Control Valves		21 (3050)	FHG		02	03	06	10											289
Pilot Operated Flow Control and Check Valves		21 (3050)	FHCG		02	03	06	10											289
Restrictors		25 (3630)	SRT/SRG		03	06	10	SRF-16										(Rated Flow)★	299
One Way Restrictors		25 (3630)	SRCT/SRCG		03	06	10	SRCF-16										(Rated Flow)★	299
Throttle Modules		25 (3630)	TC1G		01	03													305
Throttle & Check Modules		25 (3630)	TC2G		01	03													305
Deceleration Valves		21 (3050)	ZY/ZG		03	06	10												310
Deceleration & Check Valves		21 (3050)	ZCT/ZCG		03	06	10												310
Feed Control Valves		14 (2030)	UCF1G/UCF2G	01	03	04													318
Needle Valves		35 (5080)	GCT/ GCTR	02															325

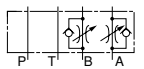
★ Rated flow stands for approximate flow rate when the pressure drop between inlet and outlet ports of the valve in fully opened condition becomes 0.3 MPa (44 PSI) maximum at fluid's specific gravity of 0.85 and kinematic viscosity of 20 mm<sup>2</sup>/s (98 SSU).

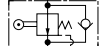
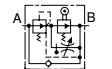
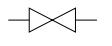
**Hydraulic Fluids**

**Fluid Types**

Any type of hydraulic fluids listed in the table below can be used.

Petroleum base oils	Use fluids equivalent to ISO VG 32 or VG 46.
Synthetic fluids	Use phosphate ester or polyol ester fluid. When phosphate ester fluid is used, prefix "F-" to the model number because the special seals (fluororubber) are required to be used.
Water containing fluids	Use water-glycol fluid.

Note: For use with hydraulic fluids other than those listed above, please consult your Yuken representatives in advance.

**Recommended Viscosity and Oil Temperatures**

Use hydraulic fluids which satisfy the recommended viscosity and oil temperatures given below.

Name	Viscosity	Temperature
Flow Control Valves Flow Control and Check Valves Pilot Operated Flow Control Valves Pilot Operated Flow Control and Check Valves Feed Control Valves	20 - 200 mm <sup>2</sup> /s (98 - 900 SSU)	-15 - +70°C (5 - 158°F)
Restrictors One Way Restrictors Throttle Modules Throttle and Check Modules Deceleration Valves Deceleration and Check Valves Needle Valves	15 - 400 mm <sup>2</sup> /s (77 - 1800 SSU)	

**Control of Contamination**

Due caution must be paid to maintaining control over contamination of the hydraulic fluids which may otherwise lead to breakdowns and shorten the life of the valves. Please maintain the degree of contamination within NAS 1638-Grade 12. Use 25 μm or finer line filter.

## Flow Control Valves / Flow Control and Check Valves

These valves are pressure and temperature compensating type valves and maintain a constant flow rate independent of change in system pressure (load) and temperature (viscosity of the fluid). They control flow rate of the hydraulic circuit and eventually control speed of the actuator precisely. Valves with an integral check valve allow a controlled flow and reverse free flow. Repeated resetting can be made easily with a digital readout.

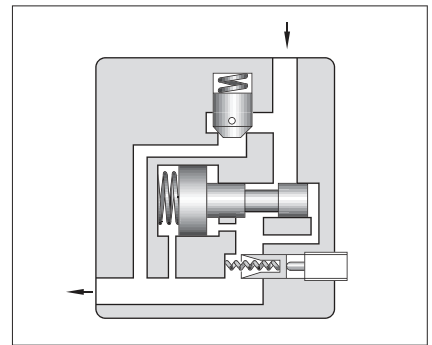
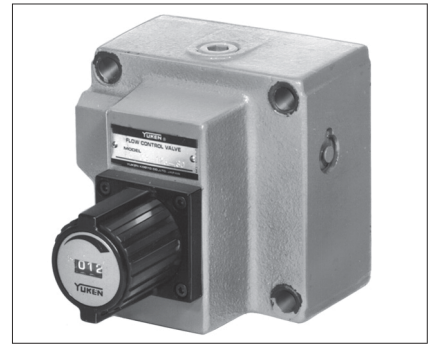

### Specifications

Model Numbers	Max. Metred Flow Capacity L/min (U.S.GPM)	Min. Metred Flow Capacity L/min (U.S.GPM)	Max. Operating Pressure MPa (PSI)	Approx. Mass kg (lbs.)
FG FCG -01- $\frac{4}{8}$ -*-11*	4(1.06) 8(2.1)	0.02(.005) {0.04 (.011)} ★	14 (2030 )	1.3 (2.9)
FG FCG -02-30-*-30*	30(7.9)	0.05 (.013)	21 (3050)	3.8 (8.4)
FG FCG -03-125-*-30*	125(33)	0.2 (.053)		7.9 (17.4)
FG FCG -06-250-*-30*	250(66)	2 (.53)		23 (50.7)
FG FCG -10-500-*-30*	500(132)	4 (1.06)		52 (115)

★ The figures in the brace are for pressures above 7 MPa (1020 PSI).

### Model Number Designation

F-	FC	G	-01	-8	-N	-11	*
Special Seals	Series Number	Type of Mounting	Valve Size	Max. Metred Flow Capacity L/min (U.S.GPM)	Pres. Compensator Stroke Adjustment	Design Number	Design Standards
<b>F:</b> Special Seals for Phosphate Ester Type Fluids (Omit if not required)	<b>F:</b> Flow Control Valves  <b>FC:</b> Flow Control and Check Valves	<b>G:</b> Sub-plate Mounting	<b>01</b>	<b>4 : 4 (1.06)</b> <b>8 : 8 (2.1)</b>	<b>N:</b> Applicable only for Pres. Compensator Stroke Adjustment (Option - Omit if not required)	<b>11</b>	Refer to ★
			<b>02</b>	<b>30 : 30 (7.9)</b>		<b>30</b>	
			<b>03</b>	<b>125 : 125 (33)</b>		<b>30</b>	
			<b>06</b>	<b>250 : 250 (66)</b>		<b>30</b>	
			<b>10</b>	<b>500 : 500 (132)</b>		<b>30</b>	

★ Design Standards: None.....Japanese Standard "JIS" and European Design Standard 90.....N. American Design Standard

### Attachment

#### Mounting Bolts

Valve Model Numbers	Socket Head Cap Screw		Qty.
	Japanese Std. "JIS" & European Design Std.	N. American Design Std.	
FG/FCG-01	M5 × 55 Lg.	No.10-24 UNC × 2-1/4 Lg.	4
FG/FCG-02	M8 × 50 Lg.	5/16-18 UNC × 2 Lg.	4
FG/FCG-03	M10 × 75 Lg.	3/8-16 UNC × 3 Lg.	4
FG/FCG-06	M16 × 130 Lg.	5/8-11 UNC × 5 Lg.	4
FG/FCG-10	M20 × 160 Lg.	3/4-10 UNC × 6-1/2 Lg.	4

### Graphic Symbols



FG

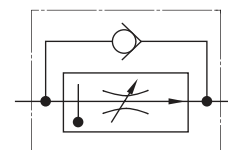

FCG

### Option

#### Pres. compensator stroke adjustment

Can reduce jumping at the start of the actuator.

## Sub-plate

Valve Model Numbers	Japanese Standard "JIS"		European Design Std.		N. American Design Std.		Approx. Mass kg (lbs.)
	Sub-plate Model No.	Thread Size	Sub-plate Model No.	Thread Size	Sub-plate Model No.	Thread Size	
FG FCG-01	FGM-01X-10	Rc 1/4	FGM-01X-1080	1/4 BSP.F	FGM-01X-1090	1/4 NPT	0.8 (1.8)
FG FCG-02	FGM-02-20	Rc 1/4	FGM-02-2080	1/4 BSP.F	FGM-02-2090	1/4 NPT	2.3 (5.1)
	FGM-02X-20	Rc 3/8	FGM-02X-2080	3/8 BSP.F	FGM-02X-2090	3/8 NPT	2.3 (5.1)
	FGM-02Y-20	Rc 1/2	FGM-02Y-2080	1/2 BSP.F	FGM-02Y-2090	1/2 NPT	3.1 (6.8)
FG FCG-03	FGM-03-20	Rc 3/8	FGM-03-2080	3/8 BSP.F	FGM-03-2090	3/8 NPT	3.9 (8.6)
	FGM-03X-20	Rc 1/2	FGM-03X-2080	1/2 BSP.F	FGM-03X-2090	1/2 NPT	3.9 (8.6)
	FGM-03Y-20	Rc 3/4	FGM-03Y-2080	3/4 BSP.F	FGM-03Y-2090	3/4 NPT	5.7 (12.6)
	FGM-03Z-20	Rc 1	FGM-03Z-2080	1 BSP.F	FGM-03Z-2090	1 NPT	5.7 (12.6)
FG FCG-06	FGM-06X-20	Rc 1	FGM-06X-2080	1 BSP.F	FGM-06X-2090	1 NPT	12.5 (27.6)
	FGM-06Y-20	Rc 1-1/4	FGM-06Y-2080	1-1/4 BSP.F	FGM-06Y-2090	1-1/4 NPT	16 (35.3)
	FGM-06Z-20	Rc 1-1/2	FGM-06Z-2080	1-1/2 BSP.F	FGM-06Z-2090	1-1/2 NPT	16 (35.3)
FG FCG-10	FGM-10Y-20★	1-1/2, 2	FGM-10Y-20★	1-1/2, 2	FGM-10Y-2090★	1-1/2, 2	37 (81.6)

● Sub-plates are available. Specify the sub-plate model number from the table above. When sub-plates are not used, the mounting surface should have a good machined finish.

★ FGM-10Y is special type sub-plate to be used with pipe flange. When ordering FGM-10Y, specify pipe flange kit in addition to FGM-10Y referring to F3 pipe flanges show on [page 821](#).

## Instructions

### ● Min. required pressure difference

The minimum differential pressure between inlet and outlet port is required to obtain the optimum pressure compensation. It varies according to the flow rate to be set. For details, please refer to the performance curves.

### ● Free flow

Check valve pressure drops vary with flow rates. If models with check valves are used, see free flow pressure drop characteristics.

### ● Flow adjustment

[F\*G-01]

Loosen the locking screw and turn the flow adjustment dial clockwise for increase, and anti-clockwise for decrease. The dial makes about 4 revolutions from zero to full flow and the valve opening is indicated on the revolution indicator. (Refer to characteristics of "Metred Flow vs. Dial Position").

After flow adjustments, tighten the locking screw.

[F\*G-02, 03, 06, 10]

Loosen the locking screw and turn the flow adjustment handle clockwise for increase, and anti-clockwise for decrease. Open condition is indicated in digital-scale in built-in revolution indicator (Refer to the characteristics of "Metred Flow vs. Dial Position").

After flow adjustments, tighten the locking screw.

### ● Line filter

To carry out flow adjustments by as small degree as 2 L/min (.53 U.S.GPM) or less, be sure to use a line filter of 10 μm or finer and install it near the valve inlet.

FG/FCG-01-\*\*-11/1190

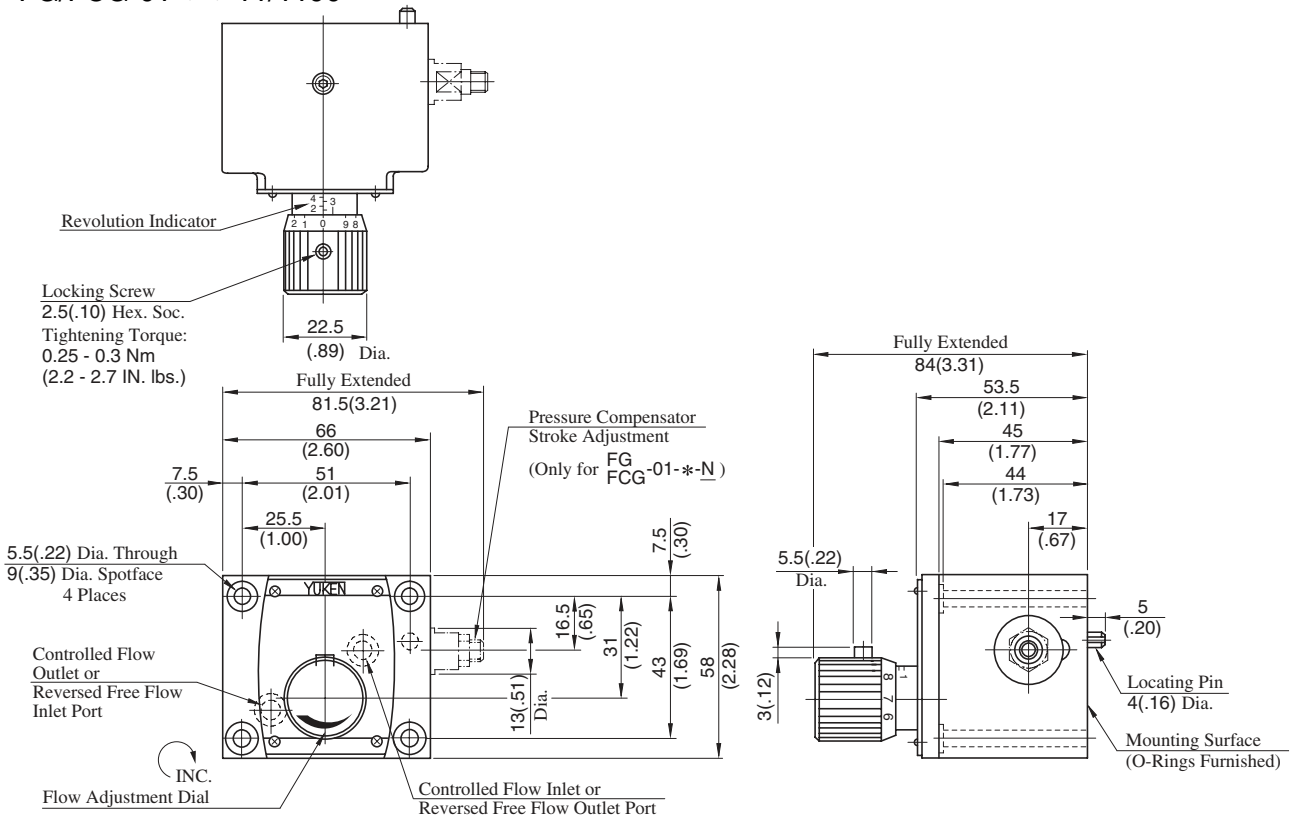

DIMENSIONS IN  
MILLIMETRES (INCHES)

Mounting surface:  
F\*G-02: ISO 6263-AB-06-4-B  
F\*G-03: ISO 6263-AK-07-2-A

FG/FCG-02-30-\*\*-30/3090  
FG/FCG-03-125-\*\*-30/3090

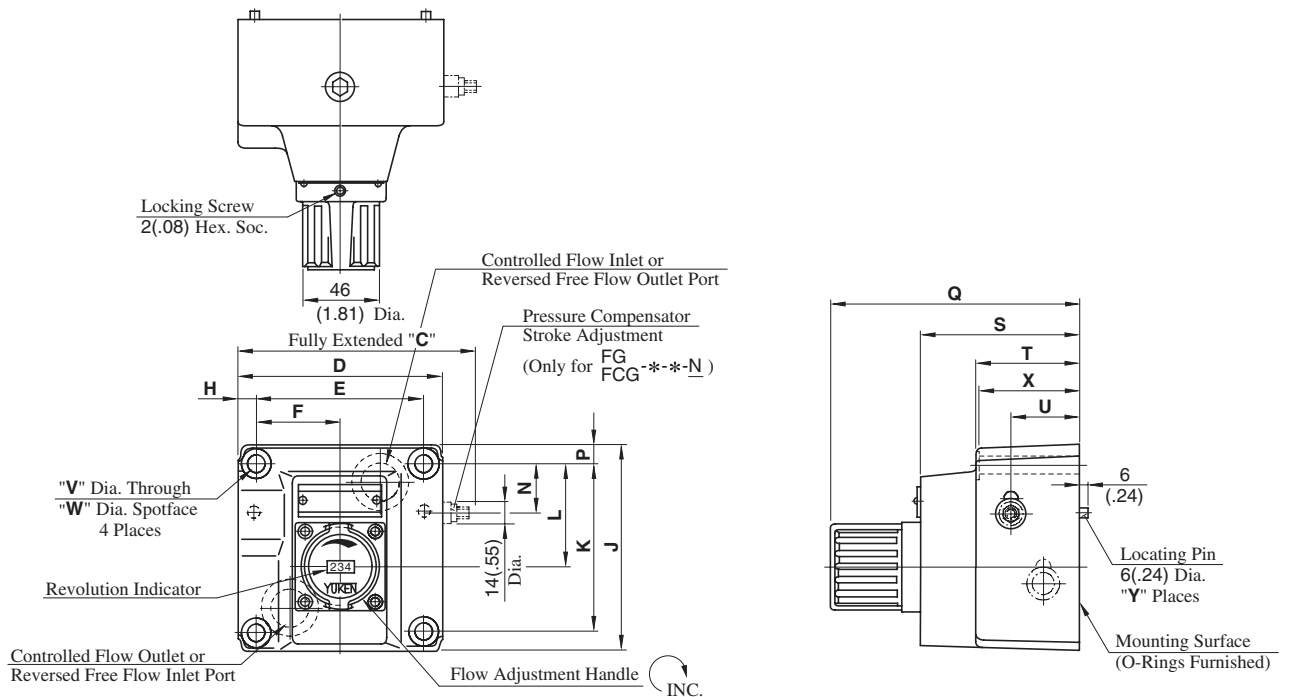

Model No.	Dimensions mm (Inches)																	Y
	C	D	E	F	H	J	K	L	N	P	Q	S	T	U	V	W	X	
FG FCG-02	116 (4.57)	96 (3.78)	76.2 (3.00)	38.1 (1.50)	9.9 (.39)	104.5 (4.11)	82.6 (3.25)	44.3 (1.74)	24 (.94)	9.9 (.39)	123 (4.84)	69 (2.72)	40 (1.57)	23 (.91)	8.8 (.35)	14 (.55)	39 (1.54)	1
FG FCG-03	145 (5.71)	125 (4.92)	101.6 (4.00)	50.8 (2.00)	11.7 (.46)	125 (4.92)	101.6 (4.00)	61.8 (2.43)	29.8 (1.17)	11.7 (.46)	152 (5.98)	98 (3.86)	64 (2.52)	41 (1.61)	11 (.43)	17.5 (.69)	63 (2.48)	2

D  
Flow Control Valves  
Flow Control and Check Valves

FG/FCG-06-250-\*-30/3090  
 FG/FCG-10-500-\*-30/3090

Mounting surface:  
 F\*G-06: ISO 6263-AP-08-2-A

**DIMENSIONS IN  
 MILLIMETRES (INCHES)**

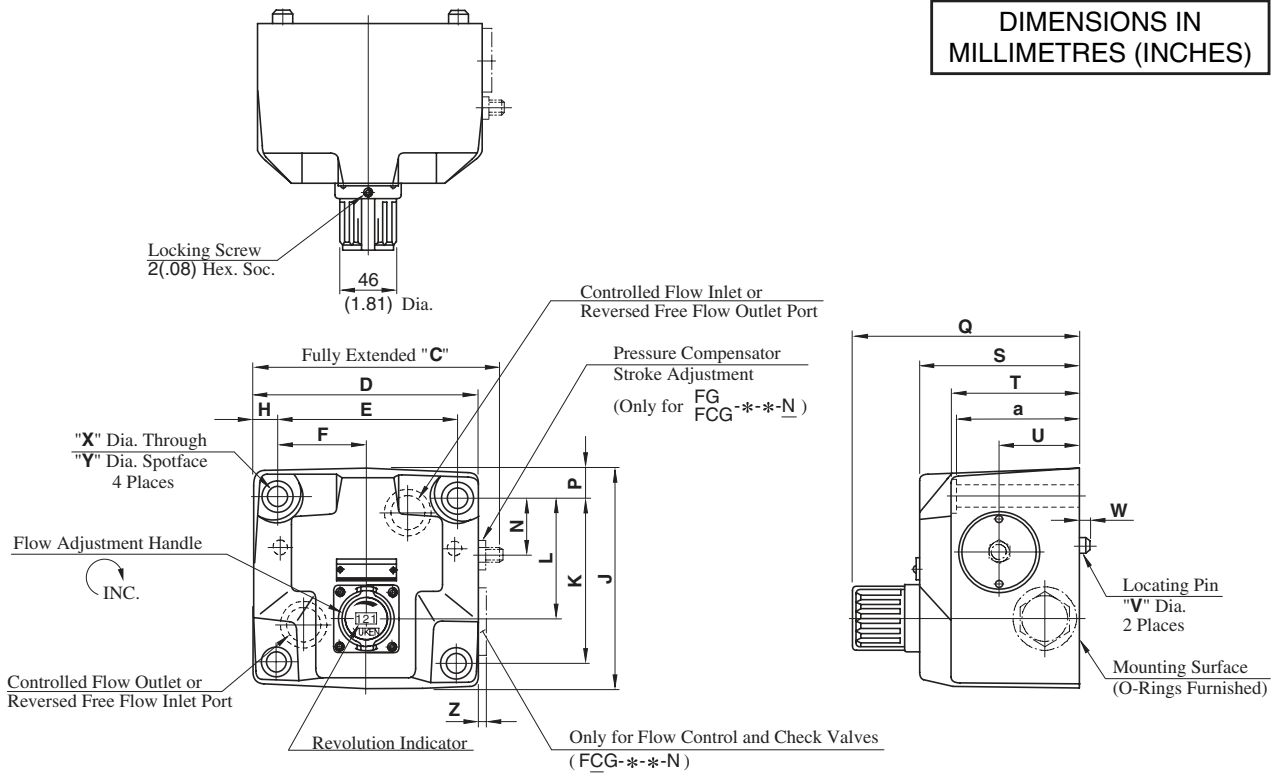

Model No.	Dimensions mm (Inches)																			
	C	D	E	F	H	J	K	L	N	P	Q	S	T	U	V	W	X	Y	Z	a
FG FCG-06	198 (7.80)	180 (7.09)	146.1 (5.75)	73 (2.87)	17 (.67)	174 (6.85)	133.4 (5.25)	99 (3.90)	44 (1.73)	20.3 (.80)	184 (7.24)	130 (5.12)	105 (4.13)	65 (2.56)	16 (.63)	7 (.28)	17.5 (.69)	26 (1.02)	10 (.39)	103 (4.06)
FG FCG-10	267 (10.51)	244 (9.61)	196.9 (7.75)	98.5 (3.88)	23.5 (.93)	228 (8.98)	177.8 (7.00)	144.5 (5.69)	61 (2.40)	25 (.98)	214 (8.43)	160 (6.30)	137 (5.39)	85 (3.35)	18 (.71)	10 (.39)	21.5 (.85)	32 (1.26)	7.5 (.30)	135 (5.31)

FGM-01X-10/1080/1090

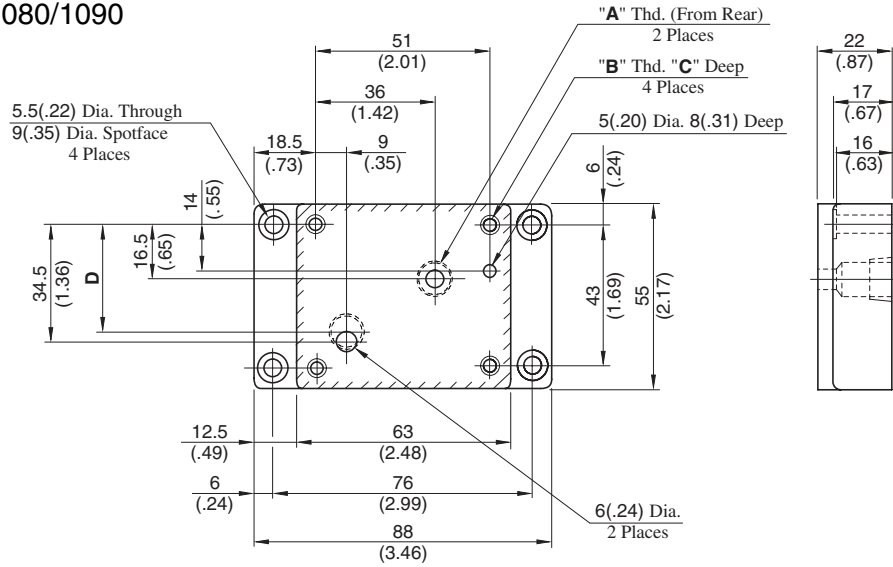

Sub-plate Model Numbers	"A" Thd.	"B" Thd.	C	D
FGM-01X-10	Rc 1/4	M5	14 (.55)	34.5 (1.36)
FGM-01X-1080	1/4 BSP.F	M5	14 (.55)	30.0 (1.18)
FGM-01X-1090	1/4 NPT	No.10-24 UNC	15 (.59)	34.5 (1.36)

DIMENSIONS IN MILLIMETRES (INCHES)

FGM-02\*-20/2080/2090

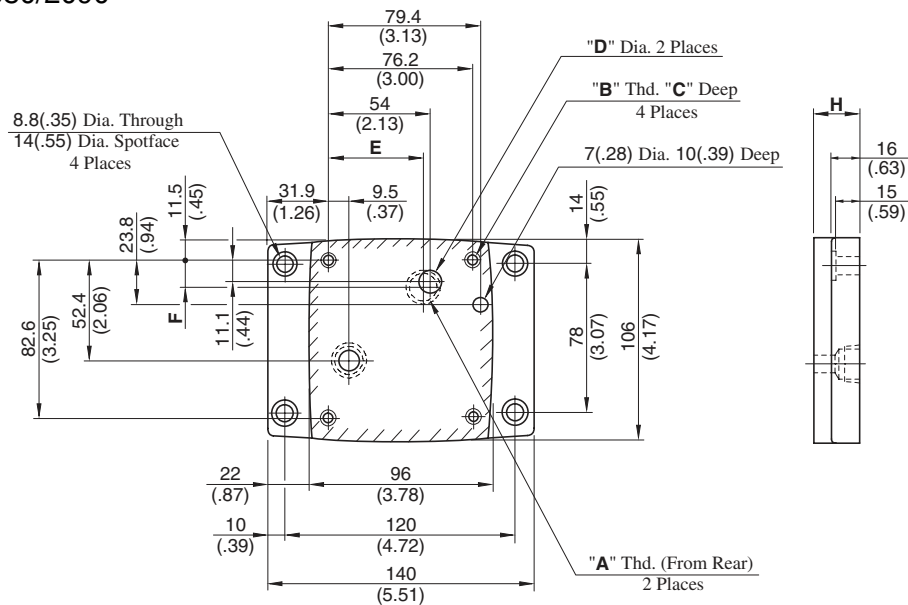

Sub-plate Model Numbers	"A" Thd.	"B" Thd.	C	D	E	F	H
FGM-02-20	Rc 1/4	M8	14 (.55)	11.0 (.43)	54 (2.13)	11.1 (.44)	25 (.98)
FGM-02-2080	1/4 BSP.F			11.7 (.46)			
FGM-02-2090	1/4 NPT	5/16-18 UNC	18 (.71)	11.0 (.43)			
FGM-02X-20	Rc 3/8	M8	14 (.55)	14.0 (.55)			
FGM-02X-2080	3/8 BSP.F			15.2 (.60)			
FGM-02X-2090	3/8 NPT	5/16-18 UNC	18 (.71)	14.0 (.55)			
FGM-02Y-20	Rc 1/2	M8	14 (.55)	14.0 (.55)	51 (2.01)	14 (.55)	35 (1.38)
FGM-02Y-2080	1/2 BSP.F			15.0 (.59)			
FGM-02Y-2090	1/2 NPT			5/16-18 UNC			

D  
Flow Control Valves  
Flow Control and Check Valves

**FGM-03\*-20/2080/2090**

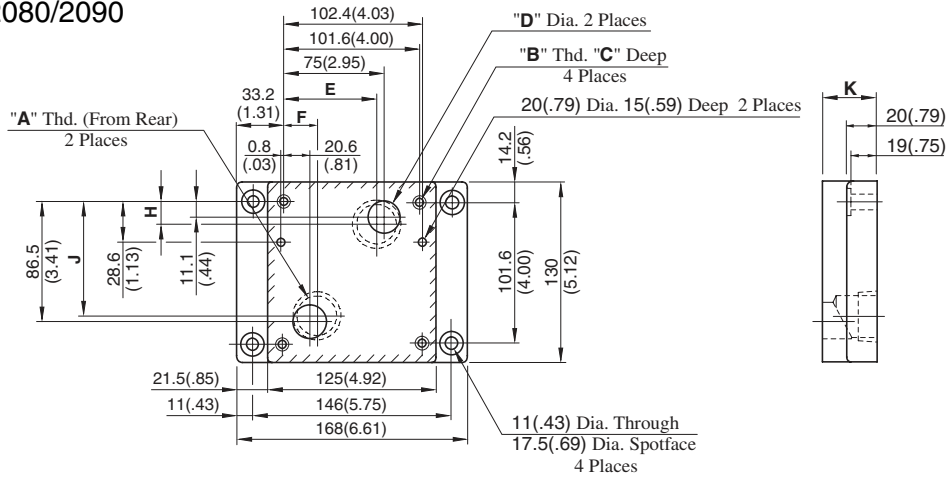

Sub-plate Model Numbers	"A" Thd.	"B" Thd.	C	D	E	F	H	J	K
FGM-03-20	Rc 3/8	M10	18 (.71)	14.0 (.55)	75 (2.95)	20.6 (.81)	11.1 (.44)	86.5 (3.41)	25 (.98)
FGM-03-2080	3/8 BSP.F		18 (.71)	15.0 (.59)					
FGM-03-2090	3/8 NPT	21 (.83)	14.0 (.55)						
FGM-03X-20	Rc 1/2	M10	18 (.71)	17.5 (.69)	70 (2.76)	25.6 (1.01)	16.1 (.63)	81.5 (3.21)	40 (1.57)
FGM-03X-2080	1/2 BSP.F		18 (.71)	19.0 (.75)					
FGM-03X-2090	1/2 NPT	21 (.83)	17.5 (.69)						
FGM-03Y-20	Rc 3/4	M10	18 (.71)	23.0 (.91)	70 (2.76)	25.6 (1.01)	16.1 (.63)	81.5 (3.21)	40 (1.57)
FGM-03Y-2080	3/4 BSP.F		18 (.71)						
FGM-03Y-2090	3/4 NPT	21 (.83)							
FGM-03Z-20	Rc 1	M10	18 (.71)	23.0 (.91)	70 (2.76)	25.6 (1.01)	16.1 (.63)	81.5 (3.21)	40 (1.57)
FGM-03Z-2080	1 BSP.F		18 (.71)						
FGM-03Z-2090	1 NPT	21 (.83)							

**DIMENSIONS IN MILLIMETRES (INCHES)**

**FGM-06\*-20/2080/2090**

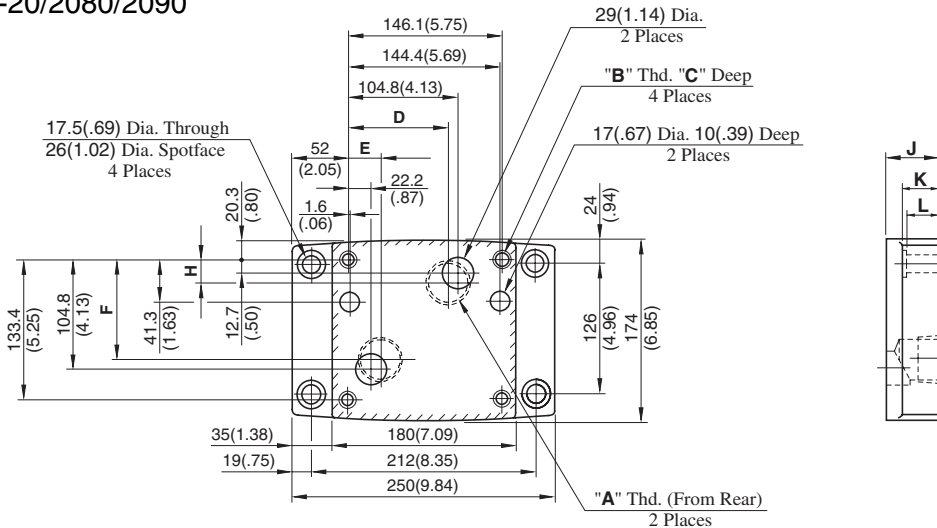

Sub-plate Model Numbers	"A" Thd.	"B" Thd.	C	D	E	F	H	J	K	L
FGM-06X-20	Rc 1	M16	30 (1.18)	104.8 (4.13)	22.2 (.87)	104.8 (4.13)	18 (.71)	45 (1.77)	35 (1.38)	34 (1.34)
FGM-06X-2080	1 BSP.F		30 (1.18)	104.8 (4.13)	22.2 (.87)	104.8 (4.13)	18 (.71)	45 (1.77)	35 (1.38)	34 (1.34)
FGM-06X-2090	1 NPT	5/8-11 UNC	35 (1.38)	104.8 (4.13)	22.2 (.87)	104.8 (4.13)	18 (.71)	45 (1.77)	35 (1.38)	34 (1.34)
FGM-06Y-20	Rc 1-1/4	M16	30 (1.18)	99 (3.90)	34 (1.34)	99 (3.90)	23 (.91)	60 (2.36)	40 (1.57)	39 (1.54)
FGM-06Y-2080	1-1/4 BSP.F		30 (1.18)							
FGM-06Y-2090	1-1/4 NPT	5/8-11 UNC	35 (1.38)							
FGM-06Z-20	Rc 1-1/2	M16	30 (1.18)	99 (3.90)	34 (1.34)	99 (3.90)	23 (.91)	60 (2.36)	40 (1.57)	39 (1.54)
FGM-06Z-2080	1-1/2 BSP.F		30 (1.18)							
FGM-06Z-2090	1-1/2 NPT	5/8-11 UNC	35 (1.38)							



FGM-10Y-20/2090

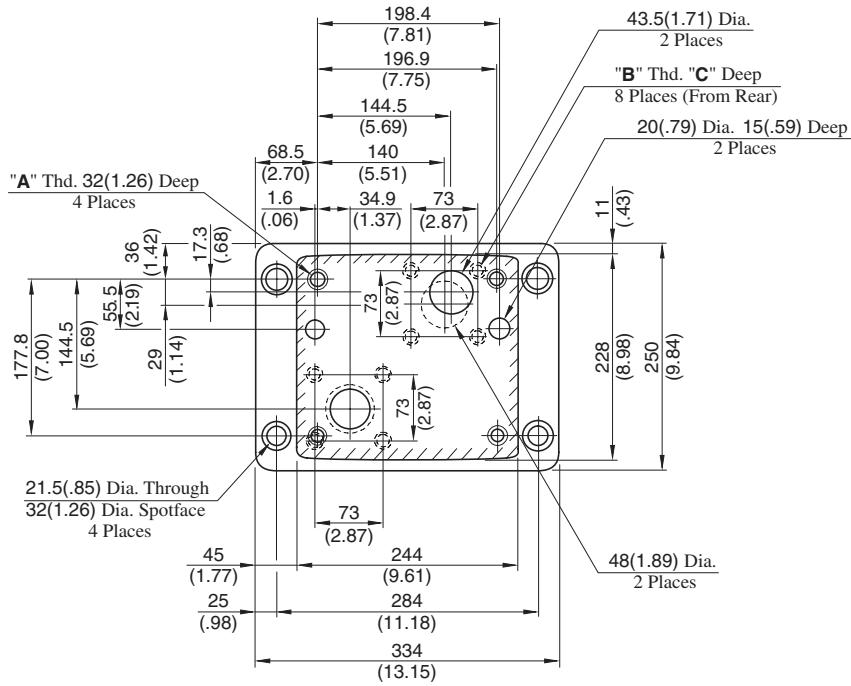

DIMENSIONS IN MILLIMETRES (INCHES)

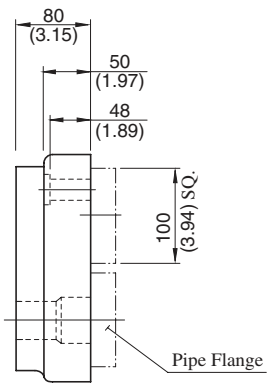

Sub-plate Model Numbers	"A" Thd.	"B" Thd.	C
FGM-10Y-20	M20	M16	32 (1.26)
FGM-10Y-2090	3/4-10 UNC	5/8-11 UNC	34 (1.34)

D

Flow Control Valves  
Flow Control and Check Valves

**Metred Flow vs. Differential Pressure**

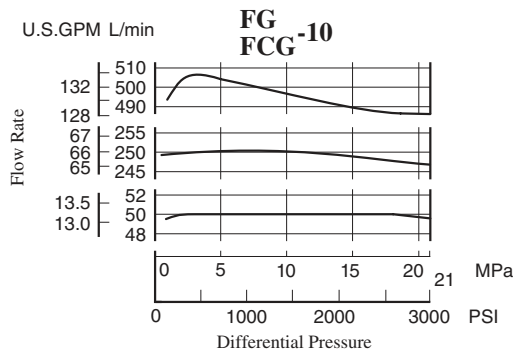
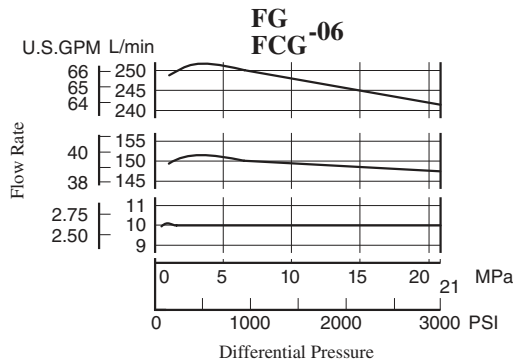
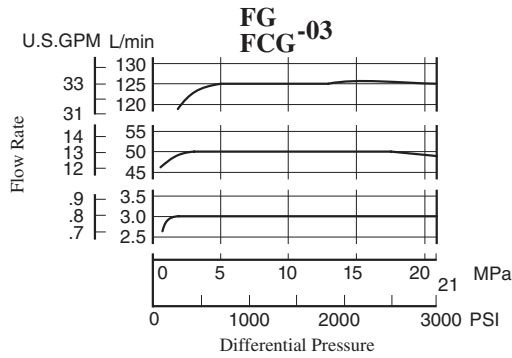
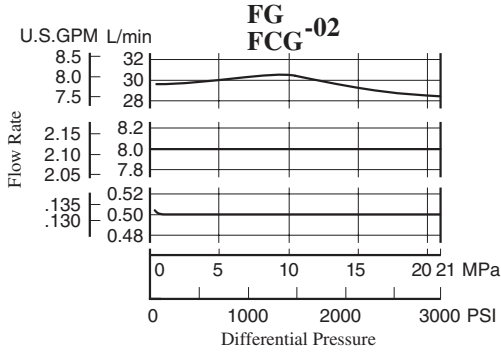
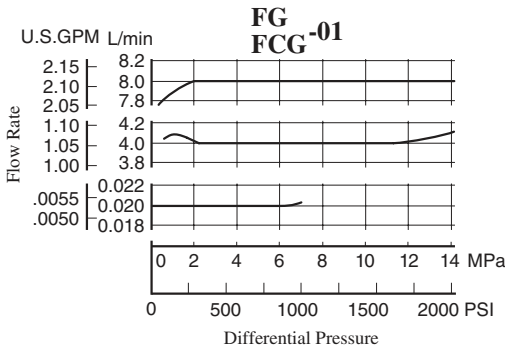

**Metred Flow vs. Viscosity**

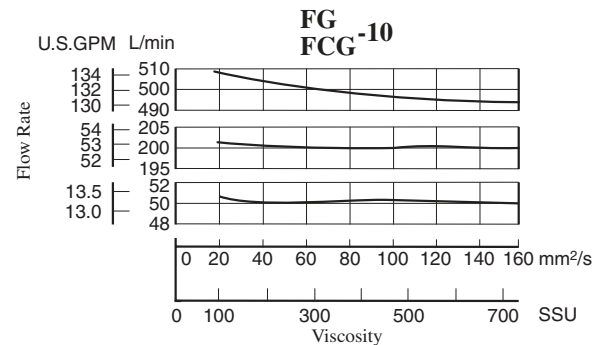
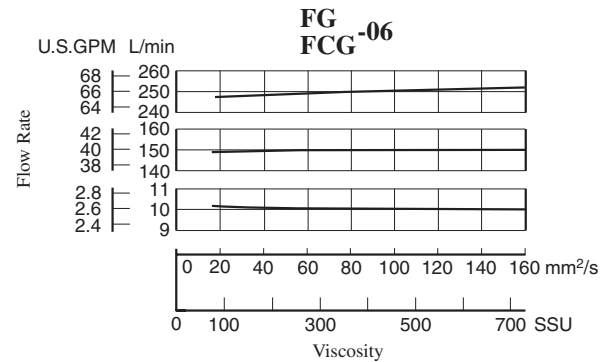
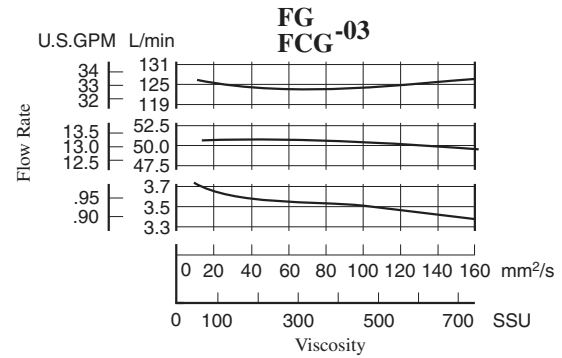
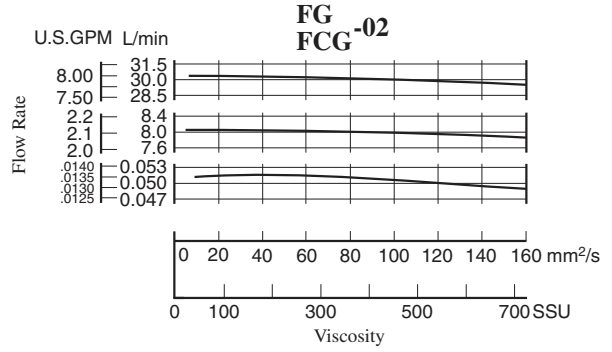
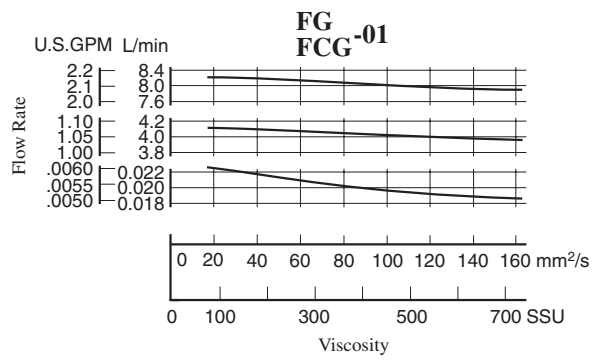

## Metred Flow vs. Dial Position

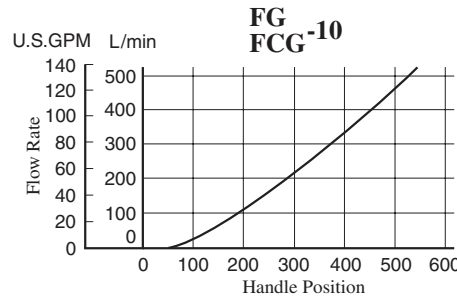
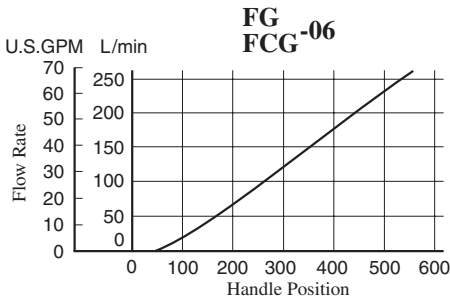
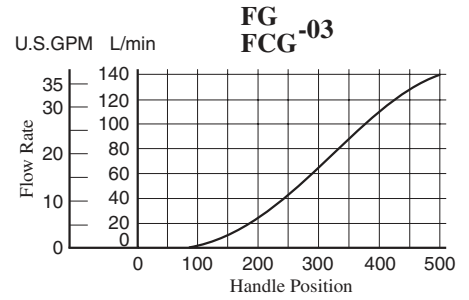
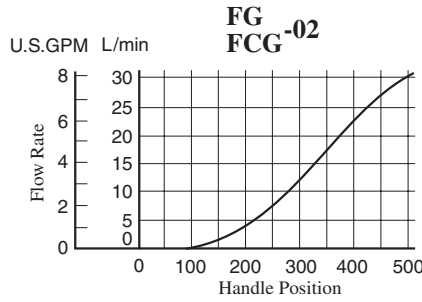
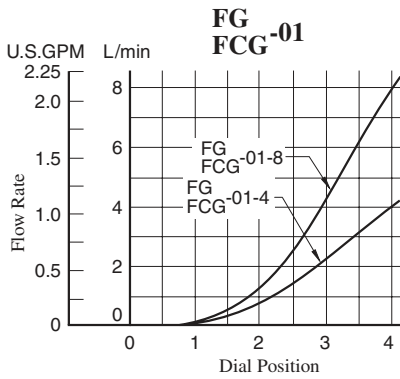

## Min. Required Pressure Difference

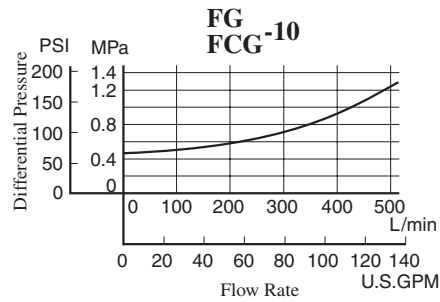
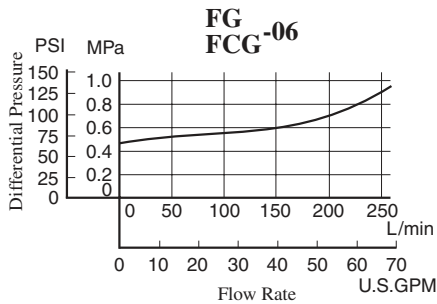
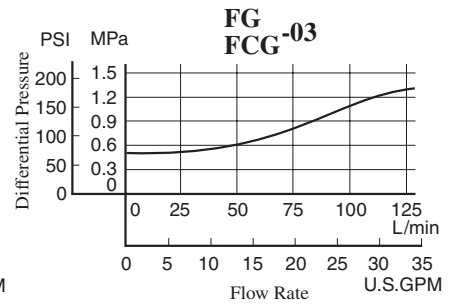
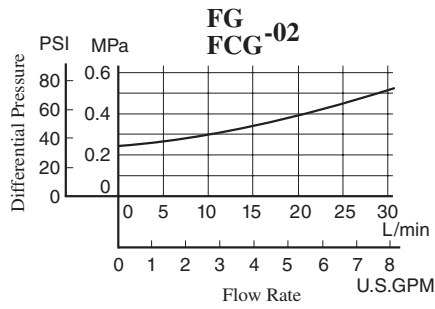
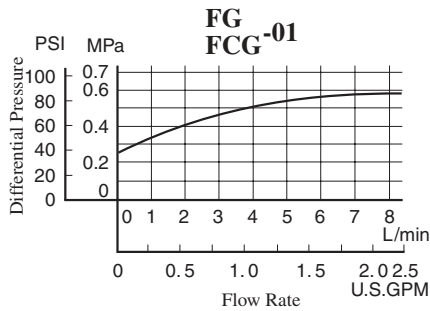

D

Flow Control Valves  
Flow Control and Check Valves

**Pressure Drop for Reversed Free Flow**

Hydraulic Fluid: Viscosity 35 mm<sup>2</sup>/s (164 SSU), Specific Gravity 0.850

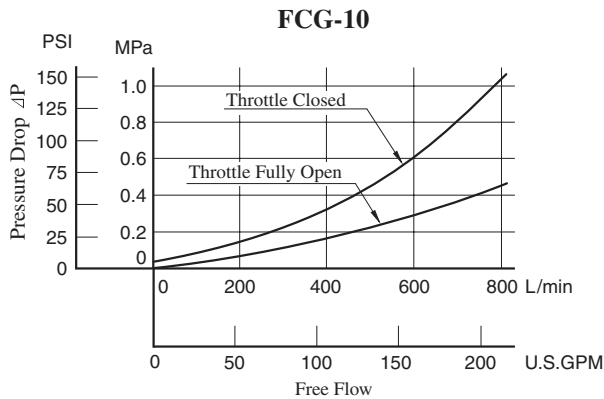
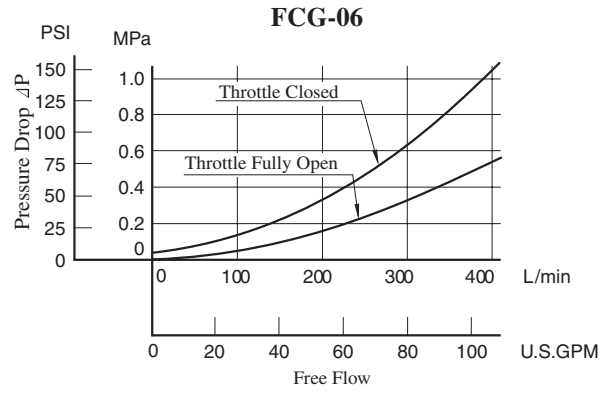
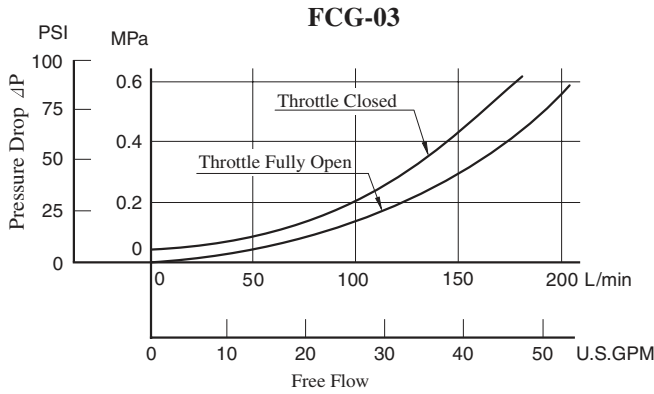
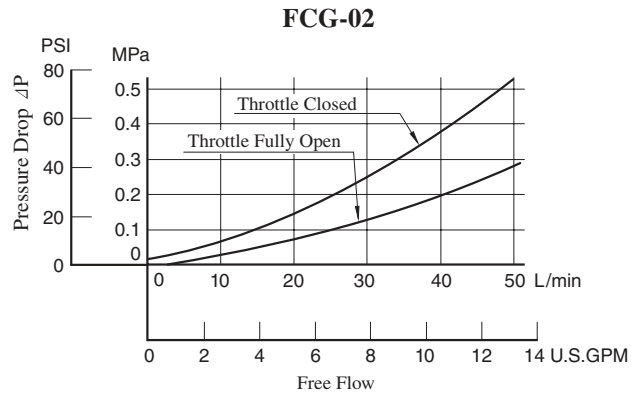
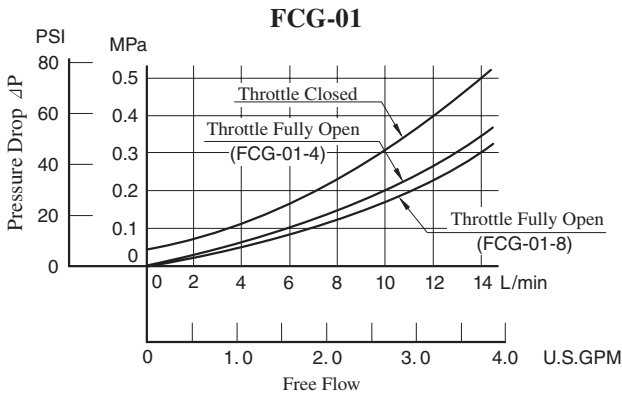

- For any other viscosity, multiply the factors in the table below.

Viscosity	mm <sup>2</sup> /s	20	40	60	80	100
	SSU	98	186	278	371	464
Factor		0.87	1.03	1.14	1.23	1.30

- For any other specific gravity (G'), the pressure drop ( $\Delta P'$ ) may be obtained from the formula below.

$$\Delta P' = \Delta P (G'/0.850)$$

## List of seals

FG  
FCG -01-\*-\*-11/1190

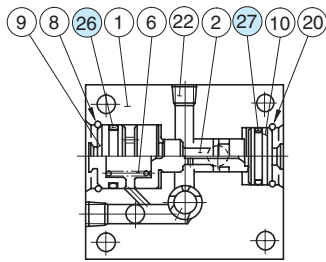

Section X-X  
(FG-01 Type)

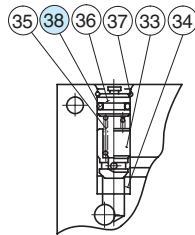

Section Y-Y  
(FCG-01 Type)

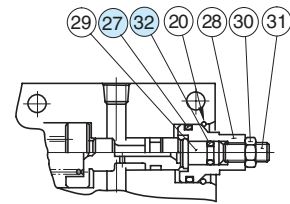

Section X-X  
(FG/FCG-01-\*-N Type)

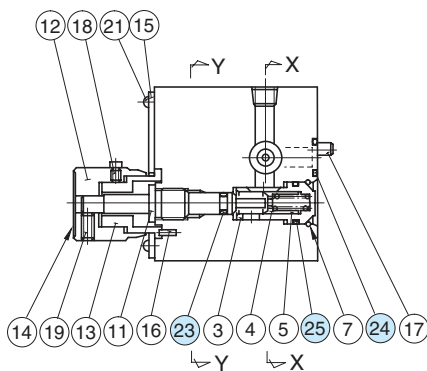

### List of Seals

Item	Name of Parts	Part Numbers	Qty.
23	O-Ring	SO-NA-P4	1
24	O-Ring	SO-NB-P9	2
25	O-Ring	SO-NB-P10	1
26	O-Ring	SO-NB-P16	1
27	O-Ring	SO-NB-P14	1
32	O-Ring	SO-NA-P5	1
38	O-Ring	SO-NB-P7	1

Note: When ordering the seals, please specify the seal kit number from the table below.

### List of Seal Kits

Valve Model Numbers	Seal Kit Numbers
FG-01	KS-FG-01-11
FCG-01	KS-FCG-01-11

FG/FCG-02-30-\*-30/3090  
FG/FCG-03-125-\*-30/3090

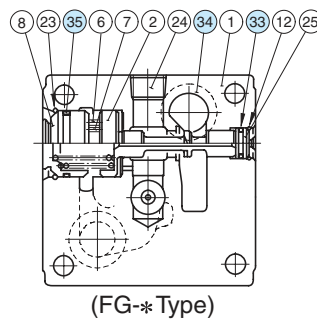
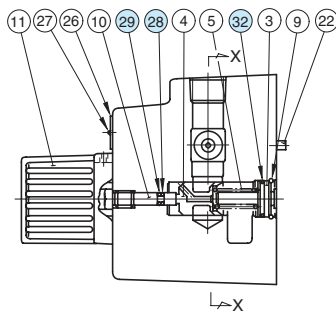

(FG-\* Type)

(FCG-\* Type)

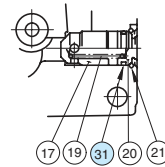

Section X-X

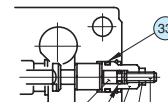

(FG/FCG-\*-N Type)

### List of Seals

Item	Name of Parts	Part Numbers		Qty.
		FG FCG-02	FG FCG-03	
28	O-Ring	SO-NA-P4	SO-NA-P4	1
29	Back Up Ring	SO-BB-P4	SO-BB-P4	1
30	O-Ring	SO-NB-P5	SO-NB-P5	1
31	O-Ring	SO-NB-P10A	SO-NB-P16	1
32	O-Ring	SO-NB-P12	SO-NB-P18	1
33	O-Ring	SO-NB-P14	SO-NB-P14	1
34	O-Ring	SO-NB-P18	SO-NB-P28	2
35	O-Ring	SO-NB-G25	SO-NB-G35	1

Note: When ordering the seals, please specify the seal kit number from the table right.

### List of Seal Kits

Valve Model Numbers	Seal Kit Numbers
FG-02	KS-FG-02-30
FCG-02	KS-FCG-02-30
FG-03	KS-FG-03-30
FCG-03	KS-FCG-03-30

FG/FCG-06-250-\*-30/3090  
 FG/FCG-10-500-\*-30/3090

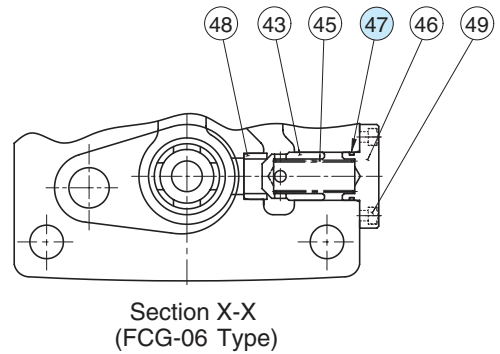
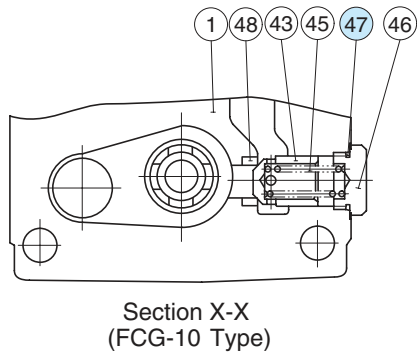
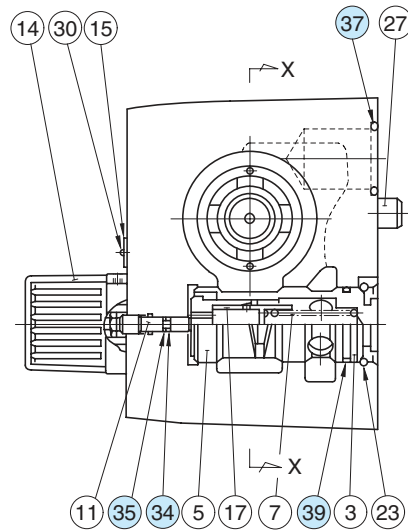
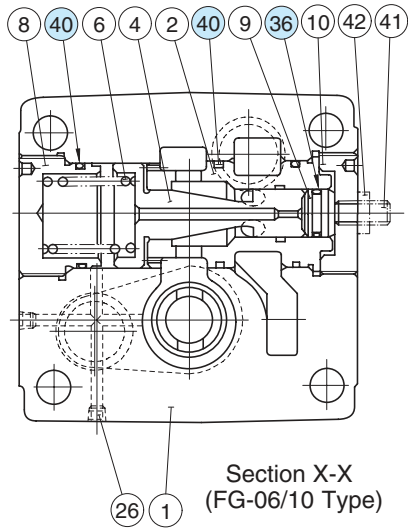

● List of Seals

Item	Name of Parts	Part Numbers		Qty.
		FG FCG-06	FG FCG-10	
34	O-Ring	SO-NA-P4	SO-NA-P4	1
35	Back Up Ring	SO-BB-P4	SO-BB-P4	1
36	O-Ring	SO-NB-P21	SO-NB-P34	1
37	O-Ring	SO-NB-P32	SO-NB-P48	2
39	O-Ring	SO-NB-P34	SO-NB-P50	1
40	O-Ring	SO-NB-P50	SO-NB-G75	3
47	O-Ring	SO-NB-A020	SO-NB-P32	1

Note: When ordering the seals, please specify the seal kit number from the table right.

● List of Seal Kits

Valve Model Numbers	Seal Kit Numbers
FG-06	KS-FG-06-30
FCG-06	KS-FCG-06-30
FG-10	KS-FG-10-30
FCG-10	KS-FCG-10-30

Pilot Operated Flow Control Valves / Pilot Operated Flow Control and Check Valves

Flow control of these valves is continuously made by a hydraulically operated pilot piston mechanism which controls opening area of the orifice of the valve. With the use of these valves, shockless operation either in acceleration or deceleration can be obtained. With the compensator for the pressure and temperature, stable flow control can be obtained regardless of the changes in the pressure (load) and temperature (oil viscosity).

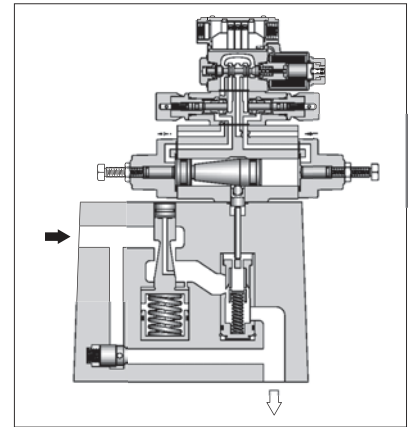
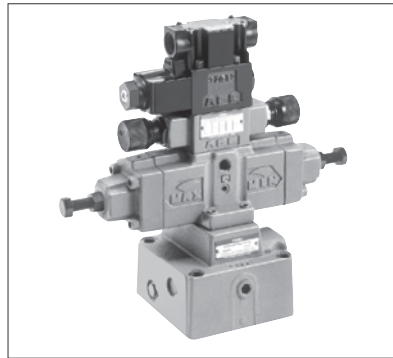

Graphic Symbols

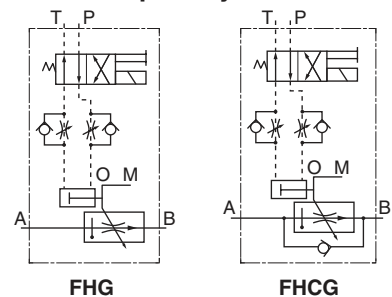

Specifications

Model Numbers	Max. Metred Flow Capacity L/min (U.S.GPM)	Min. Metred Flow Capacity L/min (U.S.GPM)	Max. Operating Pressure MPa (PSI)	Min. Pilot Pressure MPa (PSI)	Approx. Mass kg (lbs.)
FHG/FHCG-02-30-*-13*	30 (7.9)	0.05 (.013)	21 (3050)	1.5 (220)	13 (28.7)
FHG/FHCG-03-125-*-13*	125 (33)	0.2 (.053)			17 (37.5)
FHG/FHCG-06-250-*-13*	250 (66)	2 (.53)			32 (70.6)
FHG/FHCG-10-500-*-13*	500 (132)	4 (1.06)			61 (135)

Model Number Designation

F-	FHC	G	-02	-30	-N	-O	-A100	-N	-13	*
Special Seals	Series Number	Type of Mounting	Valve Size	Max. Metred Flow L/min (U.S.GPM)	Pressure <sup>*3</sup> Compensator Stroke Adj.	With No Pilot Valve <sup>*1</sup>	Coil <sup>*2</sup> Type	Type of Electrical Connections	Design Number	Design Standards
<b>F:</b> Special Seals for Phosphate Ester Type Fluids (Omit if not required)	<b>FH:</b> Pilot Operated Flow Control Valves <b>FHC:</b> Pilot Operated Flow Cont. & Check Valves	<b>G:</b> Sub-plate Mounting	<b>02</b>	<b>30:</b> 30 (7.9)	<b>N:</b> Applicable only for Pres. Compensator Stroke Adjustment (Option - Omit if not required)	<b>O:</b> Applicable only for Without Pilot Valve	<b>AC:</b> <b>A100</b> <b>A120</b> <b>A200</b> <b>A240</b> <b>DC:</b> <b>D12</b> <b>D24</b> <b>D48</b> <b>AC → DC:</b> <b>R100</b> <b>R200</b>	<b>None:</b> Terminal Box Type <b>N:</b> With Plug-in Connector (Din) <b>N:</b> With Plug-in Connector (Din)	<b>13</b>	<b>None:</b> Japanese Std. "JIS" <b>90:</b> N.American Design Std. <b>80:</b> European Design Std.
			<b>03</b>	<b>125:</b> 125 (33)					<b>13</b>	
			<b>06</b>	<b>250:</b> 250 (66)					<b>13</b>	
			<b>10</b>	<b>500:</b> 500 (132)					<b>13</b>	

- \*1. Both solenoid operated directional valve (DSG-01) and modular valve (MSW-01) can be used as a pilot valve. If no pilot valve is required, there is no need to specify the coil type and the electrical connection type of solenoid operated directional valve.
- \*2. The coil types are same as those for DSG-01 Series solenoid operated directional valves. See solenoid ratings on page 345.
- \*3. **Pres. compensator stroke adjustment:** Can reduce jumping at the start of the actuator.

In the table above, the symbols or numbers highlighted with shade represent the optional extras. The valves with model number having such optional extras are handles as options, therefore, please confirm the time of delivery with us before ordering.

Attachment  
Mounting Bolts

Valve Model Numbers	Socket Head Cap Screw		Qty.
	Japanese Std. "JIS" & European Design Std.	N. American Design Std.	
FHG/FHCG-02	M8×50 Lg.	5/16-18 UNC ×2 Lg.	4
FHG/FHCG-03	M10×75 Lg.	3/8-16 UNC ×3 Lg.	4
FHG/FHCG-06	M16×130 Lg.	5/8-11 UNC ×5 Lg.	4
FHG/FHCG-10	M20×160 Lg.	3/4-10 UNC ×6-1/2 Lg.	4

D Pilot Operated Flow Control Valves Pilot Operated Flow Control and Check Valves

**Sub-plate**

Valve Model Numbers	Japanese Standard "JIS"		European Design Std.		N. American Design Std.		Approx. Mass kg (lbs.)
	Sub-plate Model No.	Thread Size	Sub-plate Model No.	Thread Size	Sub-plate Model No.	Thread Size	
FHG FHCG -02	FGM-02-20	Rc 1/4	FGM-02-2080	1/4 BSP.F	FGM-02-2090	1/4 NPT	2.3 (5.1)
	FGM-02X-20	Rc 3/8	FGM-02X-2080	3/8 BSP.F	FGM-02X-2090	3/8 NPT	2.3 (5.1)
	FGM-02Y-20	Rc 1/2	FGM-02Y-2080	1/2 BSP.F	FGM-02Y-2090	1/2 NPT	3.1 (6.8)
FHG FHCG -03	FGM-03-20	Rc 3/8	FGM-03-2080	3/8 BSP.F	FGM-03-2090	3/8 NPT	3.9 (8.6)
	FGM-03X-20	Rc 1/2	FGM-03X-2080	1/2 BSP.F	FGM-03X-2090	1/2 NPT	3.9 (8.6)
	FGM-03Y-20	Rc 3/4	FGM-03Y-2080	3/4 BSP.F	FGM-03Y-2090	3/4 NPT	5.7 (12.6)
	FGM-03Z-20	Rc 1	FGM-03Z-2080	1 BSP.F	FGM-03Z-2090	1 NPT	5.7 (12.6)
FHG FHCG -06	FGM-06X-20	Rc 1	FGM-06X-2080	1 BSP.F	FGM-06X-2090	1 NPT	12.5 (27.6)
	FGM-06Y-20	Rc 1-1/4	FGM-06Y-2080	1-1/4 BSP.F	FGM-06Y-2090	1-1/4 NPT	16 (35.3)
	FGM-06Z-20	Rc 1-1/2	FGM-06Z-2080	1-1/2 BSP.F	FGM-06Z-2090	1-1/2 NPT	16 (35.3)
FHG FHCG -10	FGM-10Y-20★	1-1/2, 2	FGM-10Y-20★	1-1/2, 2	FGM-10Y-2090★	1-1/2, 2	37 (81.6)

- Sub-plates are available. Specify the sub-plate model number from the table above. When sub-plates are not used, the mounting surface should have a good machined finish.
- ★ FGM-10Y is special type sub-plates to be used with pipe flange. When ordering FGM-10Y, specify the pipe flange kit in addition to FGM-10Y referring to F3 pipe flanges shown on page 821.

- Sub-plates are common with flow control valves. For dimensions, see pages 281 to 283.

**Instructions**

**Control patterns and flow rate adjustment**

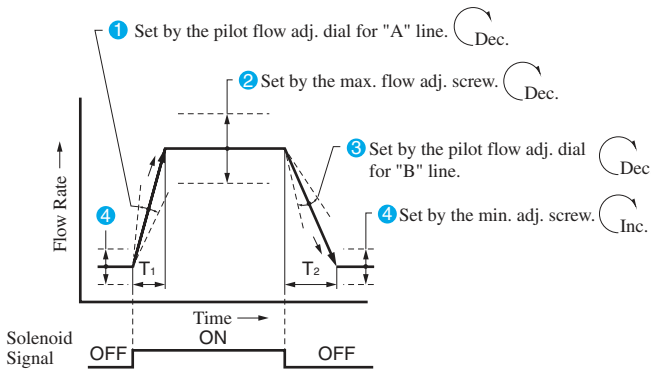

- While the solenoid operated directional valve off (4 shown left)  
The flow rate is set by the minimum flow adjustment screw and the actuator operates at the minimum speed setting.
- When the solenoid operated directional valve is turned on (1 shown left)  
The flow rate is shifted from minimum to maximum and the actuator speed is also shifted likewise. The switching time can be set by the pilot flow adjustment dial 1.
- When the solenoid operated directional valve is turned off (3 shown left)  
The flow rate is shifted from maximum to minimum and the actuator speed is also shifted likewise. The switching time can be set by the pilot flow adjustment dial 3.

**Tightening of flow adjustment screws and dials**

To adjust flow rates, slacken the lock nut or the dial setting screw. After adjustments, tighten the lock nut or the dial.

**Min. required pressure difference**

The minimum differential pressure between inlet and outlet port is required to obtain the optimum pressure compensation. It varies according to the flow rate to be set. For details, please refer to the performance curves.

**Free flow**

Check valve pressure drops vary with flow rates. If models with check valves are used, see free flow pressure drop characteristics.

**Line filter**

To carry out flow adjustments by as small degree as 2 L/min (.53 U.S.GPM) or less, be sure to use a line filter of 10 μm or finer and install it near the valve inlet.



## Metred Flow vs. Cylinders Stroke

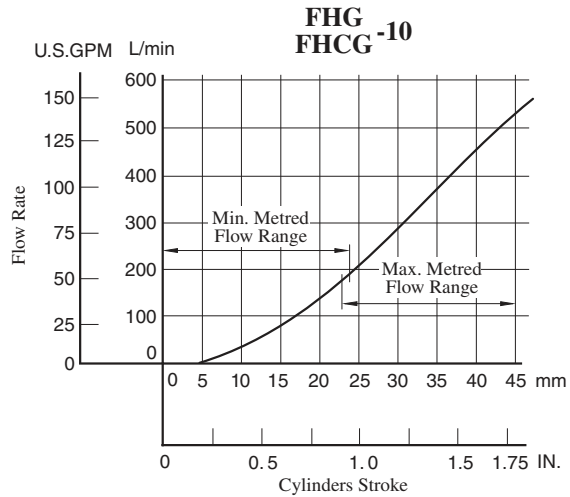
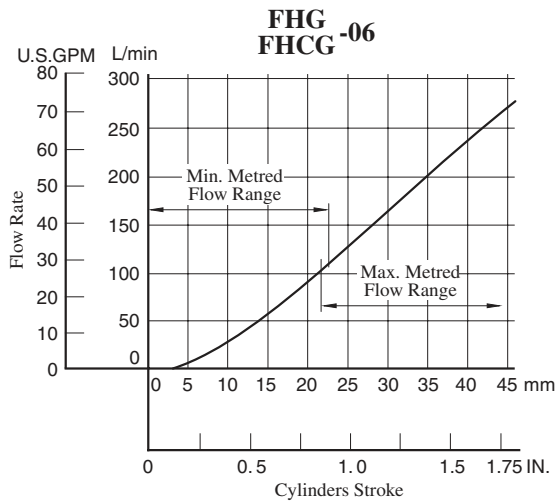
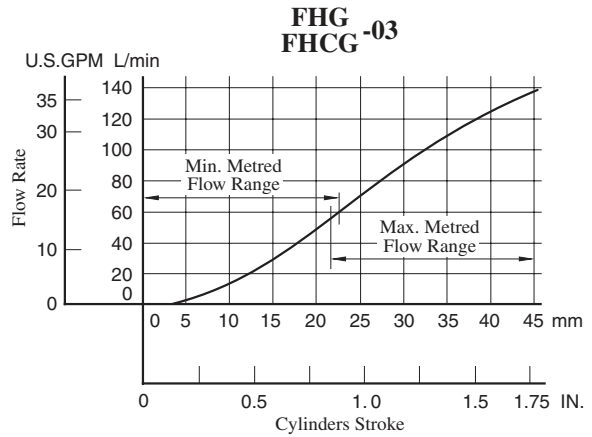
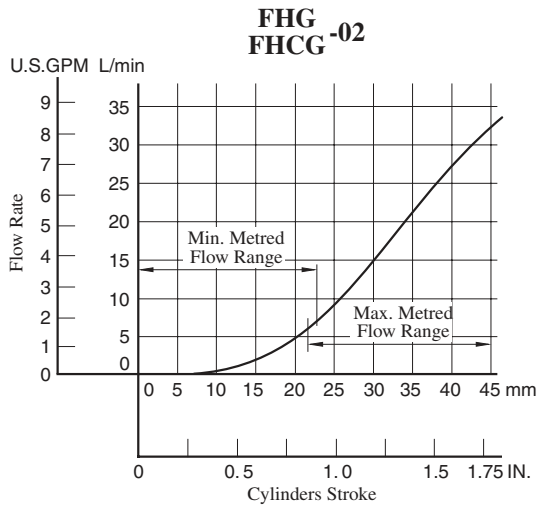

## Other Characteristics

The following characteristics are the same as for flow control valves;

- Metred Flow vs. Differential Pressure
- Metred Flow vs. Viscosity
- Min. Required Pressure Difference
- Pressure Drop for Reversed Free Flow (only for models with check valves)

See pages 284 to 286. For reference, the corresponding model No. of the flow control valves are shown below.

Valve Model No.	Model No.
FHG -02 FHCG	FG -02 FCG
FHG -03 FHCG	FG -03 FCG
FHG -06 FHCG	FG -06 FCG
FHG -10 FHCG	FG -10 FCG

D

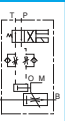

Pilot Operated Flow Control Valves  
Pilot Operated Flow Control and Check Valves

● Terminal Box Type

FHG/FHCG-02-30-\*-13/1390  
 FHG/FHCG-03-125-\*-13/1390

Mounting surface:  
 FH\*G-02: ISO 6263-AK-06-2-A  
 FH\*G-03: ISO 6263-AM-07-2-A

**DIMENSIONS IN MILLIMETRES (INCHES)**

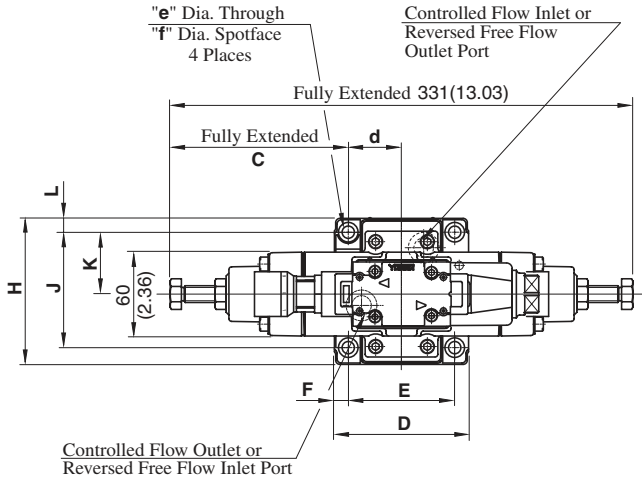

Model Numbers	n	t
FHG/FHCG-02-30-*-13	Rc 1/4	G 1/2
FHG/FHCG-02-30-*-1390	1/4 NPT	1/2 NPT
FHG/FHCG-03-125-*-13	Rc 1/4	G 1/2
FHG/FHCG-03-125-*-1390	1/4 NPT	1/2 NPT

Note: For dimensions of the valve mounting surface, see the installation drawing (P.281 and 282) of the sub-plate used together.

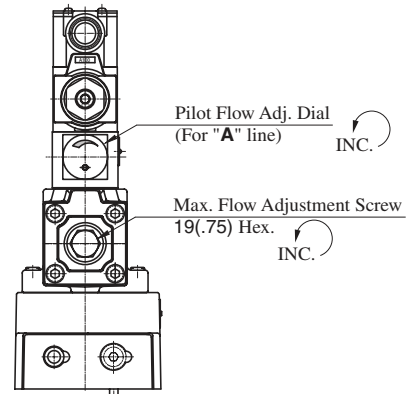
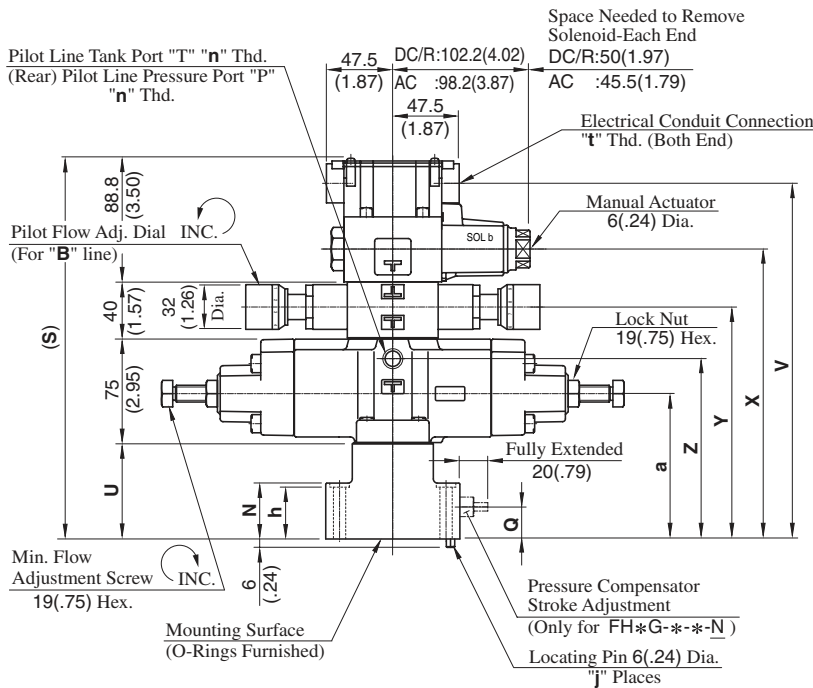

Model Numbers	Dimensions mm (Inches)															
	C	D	E	F	H	J	K	L	N	Q	S	U	V	X	Y	Z
FHG-02 FHCG-02	127.4 (5.02)	96 (3.78)	76.2 (3.00)	9.9 (.39)	100.6 (3.96)	82.6 (3.25)	44.3 (1.74)	9 (.35)	40 (1.57)	23 (.91)	272.8 (10.74)	69 (2.72)	254.5 (10.02)	207.5 (8.17)	166 (6.54)	129 (5.08)
FHG-03 FHCG-03	114.7 (4.52)	125 (4.92)	101.6 (4.00)	11.7 (.46)	125 (4.92)	101.6 (4.00)	61.8 (2.43)	11.7 (.46)	64 (2.52)	41 (1.61)	301.8 (11.88)	98 (3.86)	283.5 (11.16)	236.5 (9.31)	195 (7.68)	158 (6.22)

Model Numbers	Dimensions mm (Inches)					j
	a	d	e	f	h	
FHG-02 FHCG-02	104 (4.09)	38.1 (1.50)	8.8 (.35)	14 (.55)	39 (1.54)	1
FHG-03 FHCG-03	133 (5.24)	50.8 (2.00)	11 (.43)	17.5 (.69)	63 (2.48)	2

● **Models with Plug-in Connector**

FHG/FHCG-02-30-\*-N-13/1380/1390  
 FHG/FHCG-03-125-\*-N-13/1380/1390

**DIMENSIONS IN  
 MILLIMETRES (INCHES)**

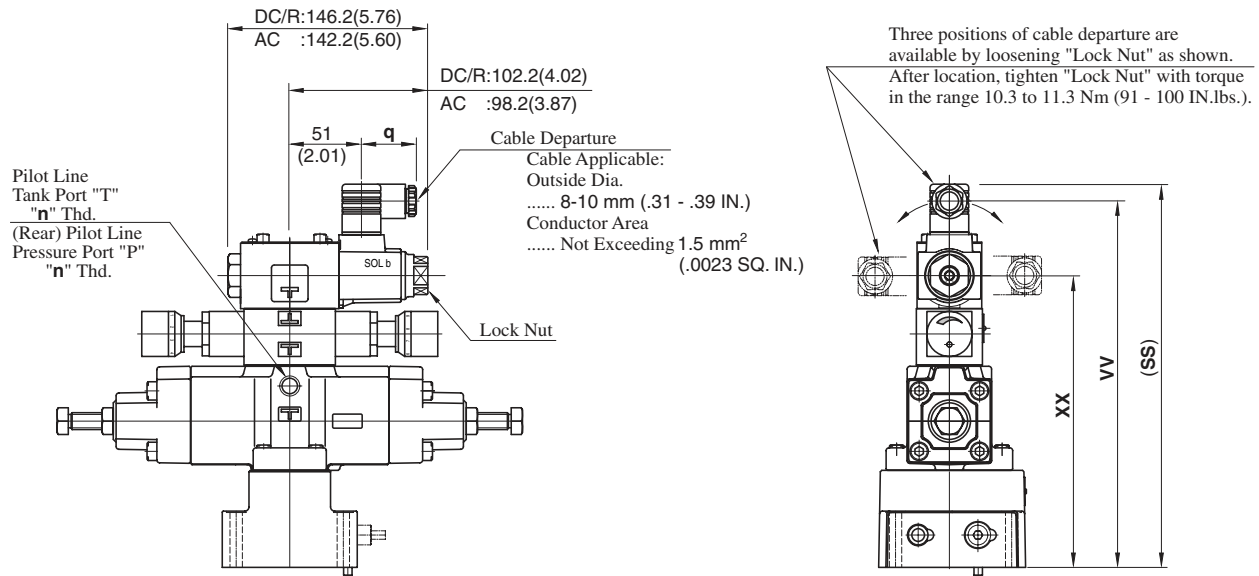

Model Numbers	Dimensions mm (Inches)				Remarks
	SS	VV	XX	q	
FHG/FHCG-02-30-*-A*-N	272.5 (10.73)	260.5 (10.26)	207.5 (8.17)	39 (1.54)	with AC Solenoid
FHG/FHCG-03-125-*-A*-N	301.5 (11.87)	289.5 (11.40)	236.5 (9.31)		
FHG/FHCG-02-30-*-D*-N	283.5 (11.16)	271.5 (10.69)	207.5 (8.17)	39 (1.54)	with DC Solenoid
FHG/FHCG-03-125-*-D*-N	312.5 (12.30)	300.5 (11.83)	236.5 (9.31)		
FHG/FHCG-02-30-*-R*-N	286.5 (11.28)	264.7 (10.42)	207.5 (8.17)	53 (2.09)	with AC → DC Solenoid
FHG/FHCG-03-125-*-R*-N	315.5 (12.42)	293.7 (11.56)	236.5 (9.31)		

Model Numbers	Thread Size		
	Japanese Std. "JIS" Design 13	European Design Std. Design 1380	N.American Design Std. Design 1390
	"n" Thd.	"n" Thd.	"n" Thd.
FHG/FHCG-02-30-*-N	Rc 1/4	1/4 BSP.F	1/4 NPT
FHG/FHCG-03-125-*-N			

● For other dimensions, refer to "Terminal Box Type".

**D**  
 Pilot Operated Flow Control Valves  
 Pilot Operated Flow Control and Check Valves

● **Terminal Box Type**

FHG/FHCG-06-250-\*-13/1390  
 FHG/FHCG-10-500-\*-13/1390

Mounting surface:  
 FH\*G-06: ISO 6263-AP-08-2-A

**DIMENSIONS IN  
 MILLIMETRES (INCHES)**

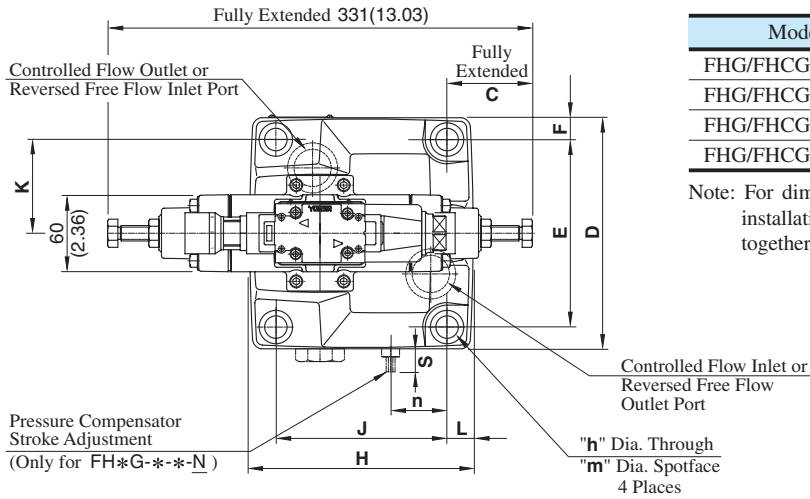

Model Numbers	q	r
FHG/FHCG-06-250-*-13	Rc 1/4	G 1/2
FHG/FHCG-06-250-*-1390	1/4 NPT	1/2 NPT
FHG/FHCG-10-500-*-13	Rc 1/4	G 1/2
FHG/FHCG-10-500-*-1390	1/4 NPT	1/2 NPT

Note: For dimensions of the valve mounting surface, see the installation drawing (P.282 and 283) of the sub-plate used together.

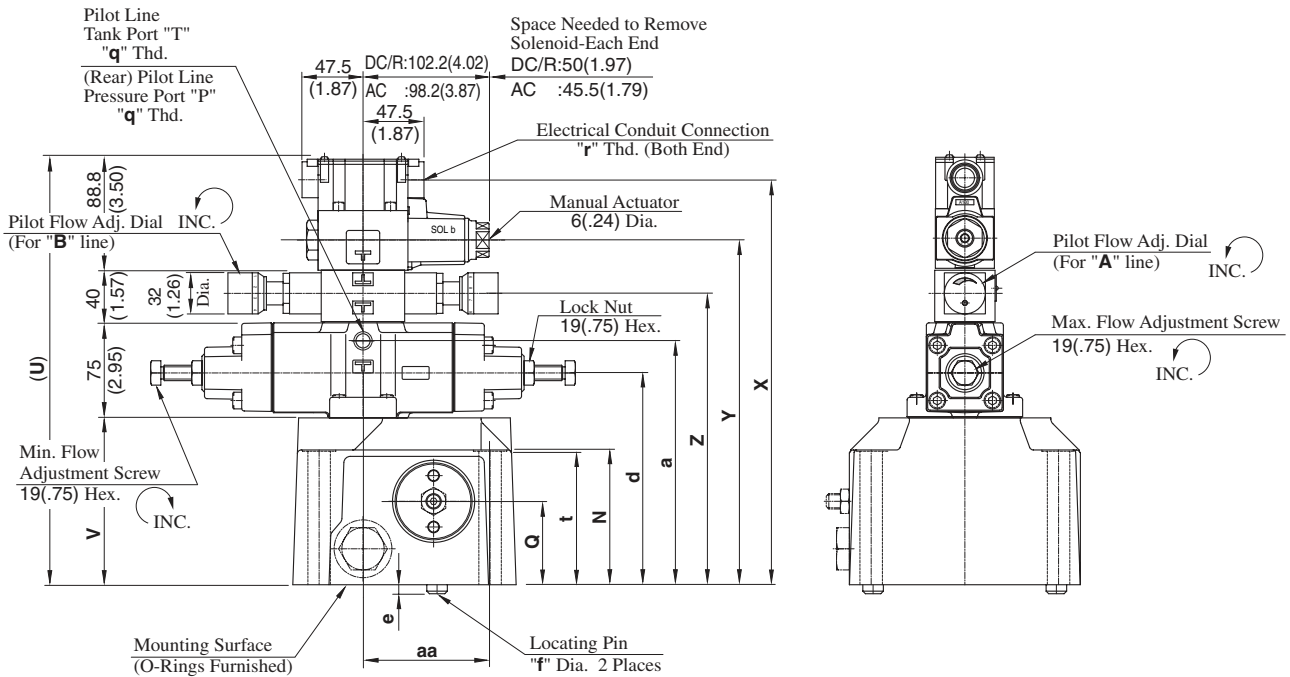

Model Numbers	Dimensions mm (Inches)															
	C	D	E	F	H	J	K	L	N	Q	S	U	V	X	Y	Z
FHG-06 FHCG-06	66.5 (2.62)	180 (7.09)	146.1 (5.75)	17 (.67)	174 (6.85)	133.4 (5.25)	73.1 (2.88)	20.3 (.80)	105 (4.13)	65 (2.56)	18 (.71)	333.8 (13.14)	130 (5.12)	315.5 (12.42)	268.5 (10.57)	227 (8.94)
FHG-10 FHCG-10	21 (.83)	244 (9.61)	196.9 (7.75)	23.5 (.93)	228 (8.98)	177.8 (7.00)	98.5 (3.88)	25.1 (.99)	137 (5.39)	85 (3.35)	23 (.91)	363.8 (14.32)	160 (6.30)	345.5 (13.60)	298.5 (11.75)	257 (10.12)

Model Numbers	Dimensions mm (Inches)								
	a	d	e	f	h	m	n	t	aa
FHG-06 FHCG-06	190 (7.48)	165 (6.50)	7 (.28)	16 (.63)	17.5 (.69)	26 (1.02)	44 (1.73)	103 (4.06)	99 (3.90)
FHG-10 FHCG-10	220 (8.66)	195 (7.68)	10 (.39)	18 (.71)	21.5 (.85)	32 (1.26)	61 (2.40)	135 (5.31)	144.5 (5.69)

● Models with Plug-in Connector

FHG/FHCG-06-250-\*-N-13/1380/1390  
 FHG/FHCG-10-500-\*-N-13/1380/1390

DIMENSIONS IN  
 MILLIMETRES (INCHES)

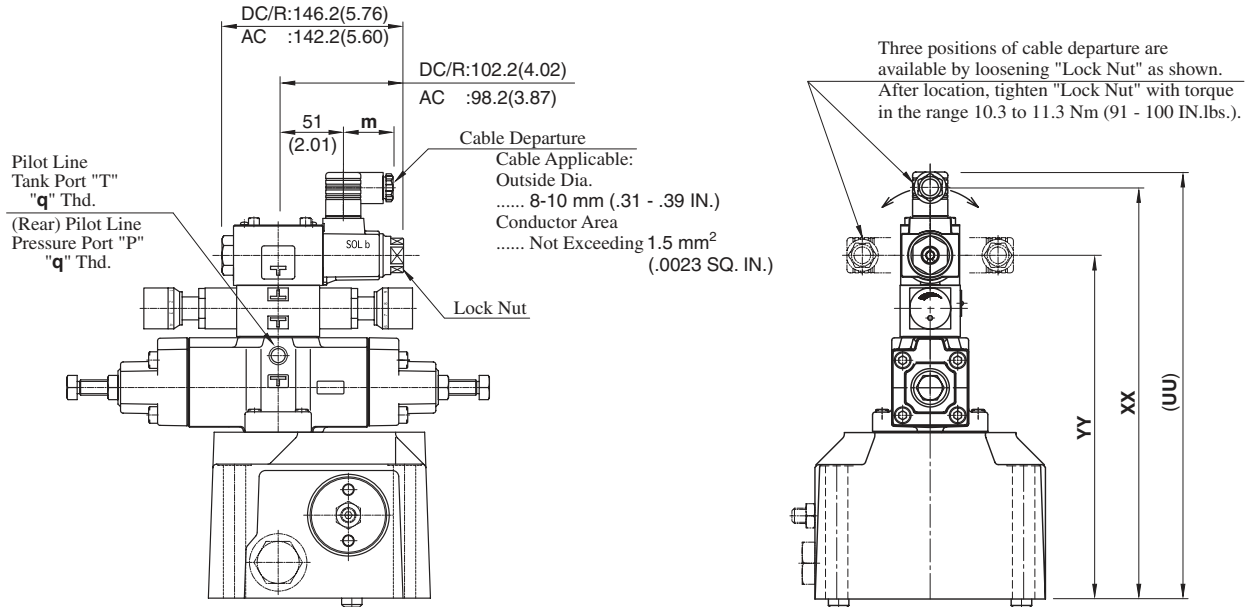

Model Numbers	Dimensions mm (Inches)				Remarks
	UU	XX	YY	m	
FHG/FHCG-06-250-*-A*-N	333.5 (13.13)	321.5 (12.66)	268.5 (10.57)	39 (1.54)	with AC Solenoid
FHG/FHCG-10-500-*-A*-N	363.5 (14.31)	351.5 (13.84)	298.5 (11.75)		
FHG/FHCG-06-250-*-D*-N	344.5 (13.56)	332.5 (13.09)	268.5 (10.57)	39 (1.54)	with DC Solenoid
FHG/FHCG-10-500-*-D*-N	374.5 (14.74)	362.5 (14.27)	298.5 (11.75)		
FHG/FHCG-06-250-*-R*-N	347.5 (13.68)	325.7 (12.82)	268.5 (10.57)	53 (2.09)	with AC → DC Solenoid
FHG/FHCG-10-500-*-R*-N	377.5 (14.86)	355.7 (14.00)	298.5 (11.75)		

Model Numbers	Thread Size		
	Japanese Std. "JIS" Design 13	European Design Std. Design 1380	N.American Design Std. Design 1390
	"q" Thd.	"q" Thd.	"q" Thd.
FHG/FHCG-06-250-*-N	Rc 1/4	1/4 BSPF	1/4 NPT
FHG/FHCG-10-500-*-N			

● For other dimensions, refer to "Terminal Box Type".

D  
 Pilot Operated Flow Control Valves  
 Pilot Operated Flow Control and Check Valves

■ List of seals

● Terminal Box Type

FHG/FHCG-02-30-\*-N-13/1390  
 FHG/FHCG-03-125-\*-N-13/1390

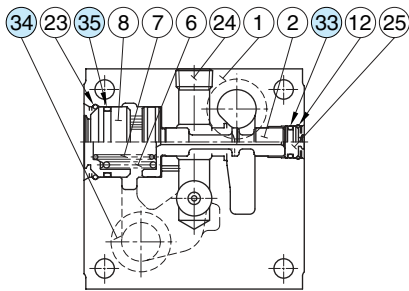
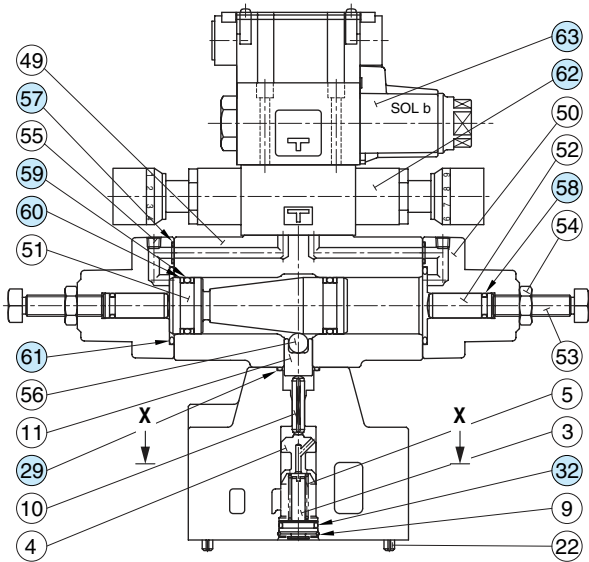

(FHG-\* Type)

● Models with Plug-in Connector

FHG/FHCG-02-30-\*-N-13/1380/1390  
 FHG/FHCG-03-125-\*-N-13/1380/1390

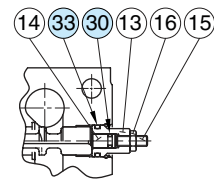
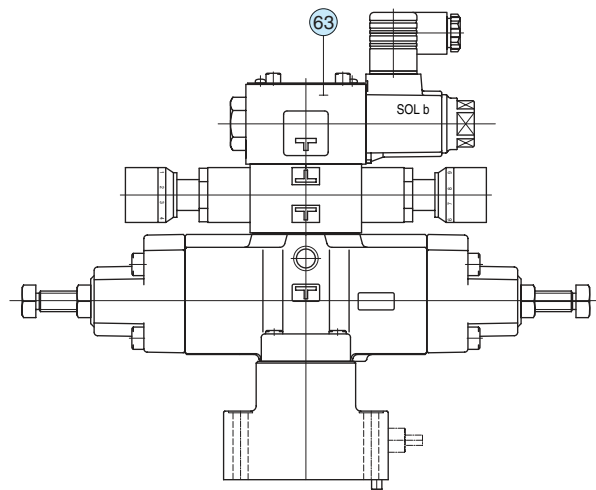

( FHG -\*-N Type )

(FHCG-\* Type)

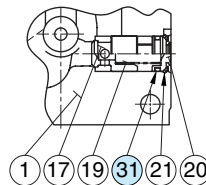

Section X-X

● List of Seals

Item	Name of Parts	Part Numbers		Qty.
		FHG -02 FHCG -02	FHG -03 FHCG -03	
29	O-Ring	SO-NB-P20	SO-NB-P20	1
30	O-Ring	SO-NB-P5	SO-NB-P5	1
31	O-Ring	SO-NB-P10A	SO-NB-P16	1
32	O-Ring	SO-NB-P12	SO-NB-P18	1
33	O-Ring	SO-NB-P14	SO-NB-P14	1
34	O-Ring	SO-NB-P18	SO-NB-P28	2
35	O-Ring	SO-NB-G25	SO-NB-G35	1
57	O-Ring	SO-NB-P9	SO-NB-P9	2
58	O-Ring	SO-NB-P10A	SO-NB-P10A	2
59	O-Ring	SO-NA-P26	SO-NA-P26	2
60	Back Up Ring	SO-BB-P26	SO-BB-P26	4
61	O-Ring	SO-NB-P38	SO-NB-P38	2

Note: When ordering the seals, please specify the seal kit number from the table right. In addition to the above seals, seals for pilot valves are included in the seal kit.

● Pilot Valves

See page 298 for the pilot valve model numbers to be used.

● List of Seal Kits

Valve Model Numbers	Seal Kit Numbers
FHG-02	KS-FHG-02-13
FHCG-02	KS-FHCG-02-13
FHG-03	KS-FHG-03-13
FHCG-03	KS-FHCG-03-13

● Terminal Box Type

FHG/FHCG-06-250-\*-\*/-13/1390  
 FHG/FHCG-10-500-\*-\*/-13/1390

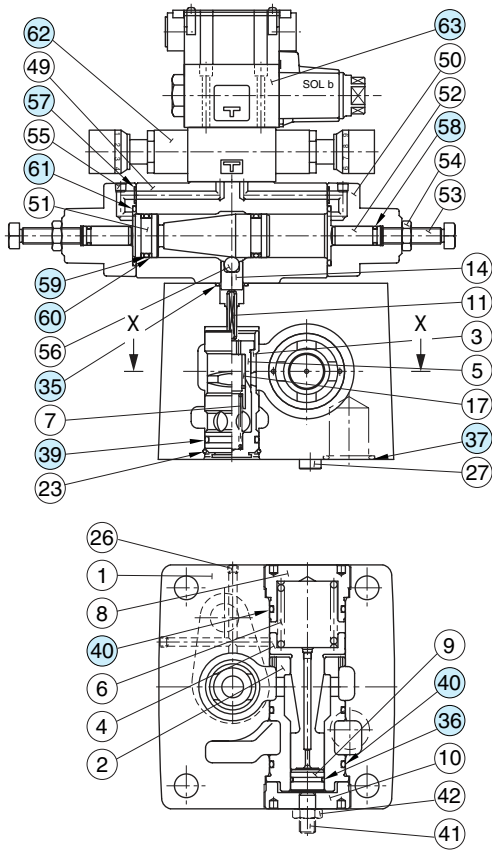

(FHG-\* Type)  
 Section X-X

● Models with Plug-in Connector

FHG/FHCG-06-250-\*-\*/-N-13/1380/1390  
 FHG/FHCG-10-500-\*-\*/-N-13/1380/1390

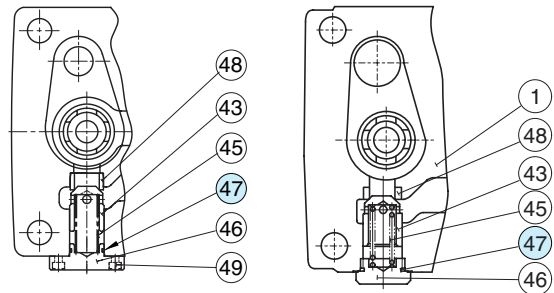
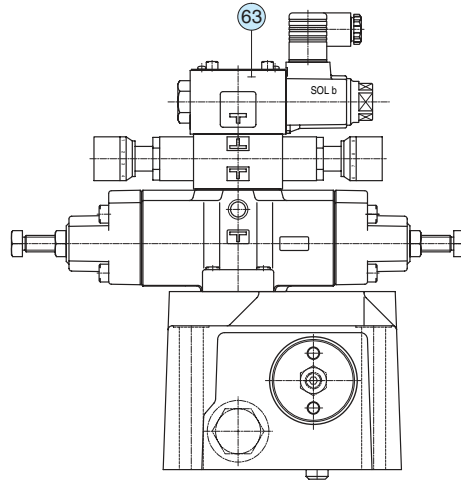

(FHCG-06 Type) (FHCG-10 Type)  
 Section X-X

● List of Seals

Item	Name of Parts	Part Numbers		Qty.
		FHG FHCG-06	FHG FHCG-10	
35	O-Ring	SO-NB-P20	SO-NB-P20	1
36	O-Ring	SO-NB-P21	SO-NB-P34	1
37	O-Ring	SO-NB-P32	SO-NB-P48	2
39	O-Ring	SO-NB-P34	SO-NB-P50	1
40	O-Ring	SO-NB-P50	SO-NB-G75	3
47	O-Ring	SO-NB-A020	SO-NB-P32	1
57	O-Ring	SO-NB-P9	SO-NB-P9	2
58	O-Ring	SO-NB-P10A	SO-NB-P10A	2
59	O-Ring	SO-NA-P26	SO-NA-P26	2
60	Back Up Ring	SO-BB-P26	SO-BB-P26	4
61	O-Ring	SO-NB-P38	SO-NB-P38	2

Note: When ordering the seals, please specify the seal kit number from the table right. In addition to the above seals, seals for pilot valves are included in the seal kit.

● Pilot Valves

See page 298 for the pilot valve model numbers to be used.

● List of Seal Kits

Valve Model Numbers	Seal Kit Numbers
FHG-06	KS-FHG-06-13
FHCG-06	KS-FHCG-06-13
FHG-10	KS-FHG-10-13
FHCG-10	KS-FHCG-10-13

■ List of Pilot Valves

● List of Pilot Valves

Type of Electrical Conduit Connections	Valve Model Numbers	Pilot Valve Model Numbers		Remarks
		Item No.62 Throttle and Check Modular Valves	Item No.63 Solenoid Operated Directional Valves	
Terminal Box Type	FHG/FHCG-02- 30-* -★ -13 FHG/FHCG-03-125-* -★ -13 FHG/FHCG-06-250-* -★ -13 FHG/FHCG-10-500-* -★ -13	MSW-01-X-50	DSG-01-2B2-★ -70	Japanese Std. "JIS"
	FHG/FHCG-02- 30-* -★ -1390 FHG/FHCG-03-125-* -★ -1390 FHG/FHCG-06-250-* -★ -1390 FHG/FHCG-10-500-* -★ -1390	MSW-01-X-50	DSG-01-2B2-★ -7090	N. American Design Std.
Plug-in Connector Type	FHG/FHCG-02- 30-* -★ -N-13 FHG/FHCG-03-125-* -★ -N-13 FHG/FHCG-06-250-* -★ -N-13 FHG/FHCG-10-500-* -★ -N-13	MSW-01-X-50	DSG-01-2B2-★ -N-70	Japanese Std. "JIS"
	FHG/FHCG-02- 30-* -★ -N-1380 FHG/FHCG-03-125-* -★ -N-1380 FHG/FHCG-06-250-* -★ -N-1380 FHG/FHCG-10-500-* -★ -N-1380	MSW-01-X-50	DSG-01-2B2-★ -N-70	European Design Std.
	FHG/FHCG-02- 30-* -★ -N-1390 FHG/FHCG-03-125-* -★ -N-1390 FHG/FHCG-06-250-* -★ -N-1390 FHG/FHCG-10-500-* -★ -N-1390	MSW-01-X-50	DSG-01-2B2-★ -N-7090	N. American Design Std.

Note: 1. Fill a coil type (a symbol representing current/voltage) in section marked ★ .  
 2. For the detail of the MSW-01 valve O-rings, see [Page 566](#).  
 3. For the detail of the DSG-01 valve O-rings, see [Page 359](#).



## Restrictors / One Way Restrictors

This valve is used to regulate an actuator speed in a circuit where line pressure is almost steady and small fluctuation of oil flow due to pressure changes is permitted. Integrated check valve allows reversed free flow from outlet to inlet port. Pressure balanced construction provides less effort in adjustment at high pressure.

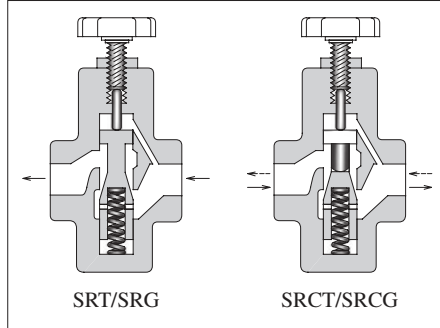

Graphic Symbols

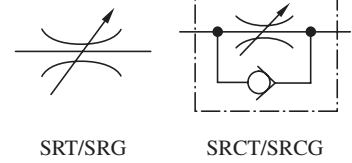

### Specifications

Valve Name	Model Numbers		Rated Flow* L/min (U.S.GPM)	Max. Operating Pres. MPa (PSI)	Approx. Mass kg (lbs.)	
	Threaded Connection	Sub-plate Mounting			Threaded Connection	Sub-plate Mounting
Restrictor	SRT-03-50/5080/5090	SRG-03-50/5090	30 (7.9)	25 (3630)	1.5 (3.3)	2.5 (5.5)
	SRT-06-50/5080/5090	SRG-06-50/5090	85 (22.4)		3.8 (8.4)	3.9 (8.6)
	SRT-10-50/5080/5090	SRG-10-50/5090	230 (60.7)		9.1 (20.1)	7.5 (16.5)
One Way Restrictor	SRCT-03-50/5080/5090	SRCG-03-50/5090	30 (7.9)	25 (3630)	1.5 (3.3)	2.5 (5.5)
	SRCT-06-50/5080/5090	SRCG-06-50/5090	85 (22.4)		3.8 (8.4)	3.9 (8.6)
	SRCT-10-50/5080/5090	SRCG-10-50/5090	230 (60.7)		9.1 (20.1)	7.5 (16.5)

\*Rated flow stands for approximate flow rate when the pressure drop between inlet and outlet ports of the valve in fully opened condition becomes 0.3 MPa (44 PSI) maximum at fluid's specific gravity of 0.85 and kinematic viscosity of 20 mm<sup>2</sup>/s (98 SSU).

#### Yuken can offer flanged connection valves described below.

For details, contact us.

Model Numbers	Rated Flow L/min (U.S.GPM)	Max. Operating Pressure MPa (PSI)
SRF/SRCF-10-50 SRF/SRCF-10-5090	230 (60.7)	25 (3630)
SRF/SRCF-16-50 SRF/SRCF-16-5090	500 (132)	

### Model Number Designation

F-	SR	T	-03	-50	*
Special Seals	Series Number	Type of Mounting	Valve Size	Design Number	Design Standards
<b>F:</b> Special Seals for Phosphate Ester Type Fluids (Omit if not required)	<b>SR:</b> Restrictor	<b>T:</b> Threaded Connection	03	50	<b>None:</b> Japanese Std. "JIS" <b>80:</b> European Design Std. <b>90:</b> N.American Design Std.
			06	50	
			10	50	
		<b>G:</b> Sub-plate Mounting	03	50	
			06	50	
			10	50	
	<b>SRC:</b> One Way Restrictor	<b>T:</b> Threaded Connection	<b>None:</b> Japanese Std. "JIS" <b>80:</b> European Design Std. <b>90:</b> N.American Design Std.	03	50
				06	50
				10	50
		<b>G:</b> Sub-plate Mounting		03	50
				06	50
				10	50

**Attachment**

**● Mounting Bolts**

Valve Model Numbers	Socket Head Cap Screw		Qty.
	Japanese Std. "JIS" and European Design Std.	N. American Design Std.	
SRG/SRCG-03	M10 × 45 Lg.	3/8-16 UNC × 1-3/4 Lg.	4
SRG/SRCG-06	M10 × 50 Lg.	3/8-16 UNC × 2 Lg.	4
SRG/SRCG-10	M10 × 55 Lg.	3/8-16 UNC × 2-1/4 Lg.	6

**Instructions**

**● Flow Adjustment**

Slacken the lock nut and turn the flow adjustment handle anti-clockwise to throttle flow. After achieving satisfactory performance tighten the lock nut.

**Sub-plate**

Valve Model Numbers	Japanese Standard "JIS"		European Design Standard		N. American Design Standard		Approx. Mass kg (lbs.)
	Sub-plate Model Numbers	Thread Size	Sub-plate Model Numbers	Thread Size	Sub-plate Model Numbers	Thread Size	
SRG SRCG-03	CRGM-03-50	Rc 3/8	CRGM-03-5080	3/8 BSP.F	CRGM-03-5090	3/8 NPT	1.6 (3.5)
	CRGM-03X-50	Rc 1/2	CRGM-03X-5080	1/2 BSP.F	CRGM-03X-5090	1/2 NPT	1.6 (3.5)
SRG SRCG-06	CRGM-06-50	Rc 3/4	CRGM-06-5080	3/4 BSP.F	CRGM-06-5090	3/4 NPT	2.4 (5.3)
	CRGM-06X-50	Rc 1	CRGM-06X-5080	1 BSP.F	CRGM-06X-5090	1 NPT	3.0 (6.6)
SRG SRCG-10	CRGM-10-50	Rc 1-1/4	CRGM-10-5080	1-1/4 BSP.F	CRGM-10-5090	1-1/4 NPT	4.8 (10.6)
	CRGM-10X-50	Rc 1-1/2	CRGM-10X-5080	1-1/2 BSP.F	CRGM-10X-5090	1-1/2 NPT	5.7 (12.6)

- Sub-plates are available. Specify the sub-plate model number from the table above. When sub-plates are not used, the mounting surface should have a good machined finish.
- Sub-plates are common with right angle check valves. For dimensions, see [page 502](#).

SRT/SRCT-03-50/5080/5090  
SRT/SRCT-06-50/5080/5090  
SRT/SRCT-10-50/5080/5090

DIMENSIONS IN  
MILLIMETRES (INCHES)

Model Numbers	Dimensions mm (Inches)								Thd. Size "N" Thd.
	C	D	E	F	H	J	K	L	
SRT/SRCT-03-50	72 (2.83)	36 (1.42)	44 (1.73)	150.5 (5.93)	53.5 (2.11)	38 (1.50) Dia.	46 (1.81)	22 (.87)	Rc 3/8
SRT/SRCT-03-5080									3/8 BSP.F
SRT/SRCT-03-5090									3/8 NPT
SRT/SRCT-06-50	100 (3.94)	50 (1.97)	58 (2.28)	180 (7.09)	66.5 (2.62)	62 (2.44) Sq.	64 (2.52)	31 (1.22)	Rc 3/4
SRT/SRCT-06-5080									3/4 BSP.F
SRT/SRCT-06-5090									3/4 NPT
SRT/SRCT-10-50	138 (5.43)	69 (2.72)	80 (3.15)	227 (8.94)	86 (3.39)	80 (3.15) Sq.	82 (3.23)	40 (1.57)	Rc 1-1/4
SRT/SRCT-10-5080									1-1/4 BSP.F
SRT/SRCT-10-5090									1-1/4 NPT

SRG/SRCG-03-50/5090

Mounting surface: ISO5781-AG-06-2-A

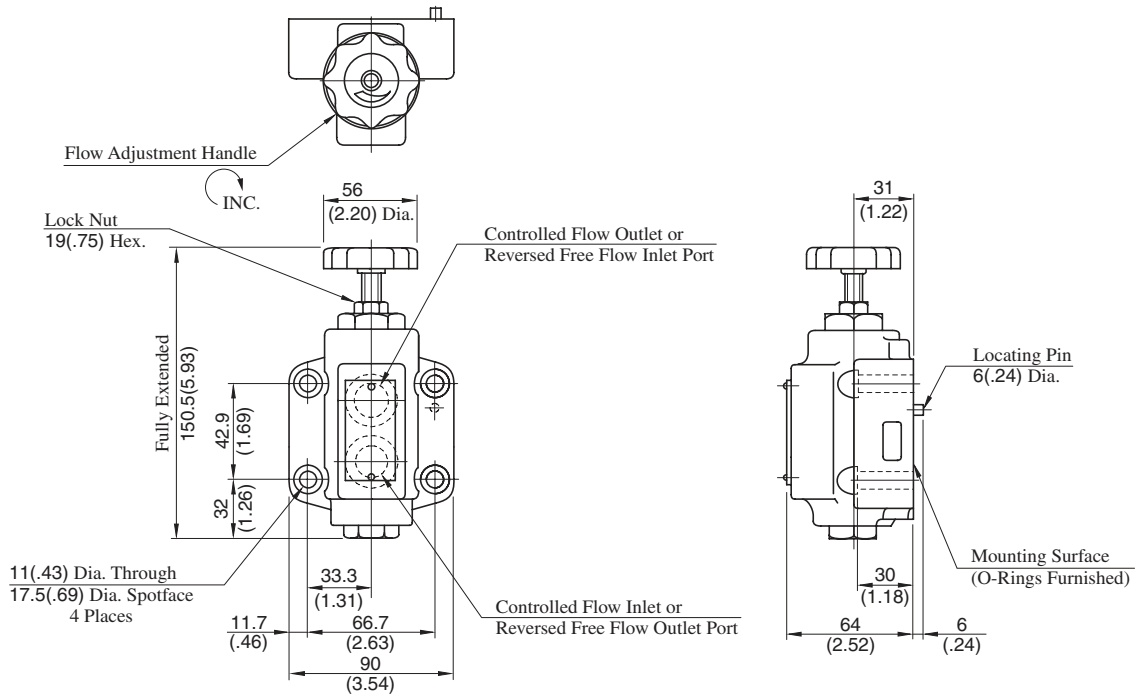

Note: For dimensions of the valve mounting surface, see the dimensional drawing (P.502) of the sub-plate used together.

DIMENSIONS IN  
MILLIMETRES (INCHES)

SRG/SRCG-06-50/5090

Mounting surface: ISO5781-AH-08-2-A

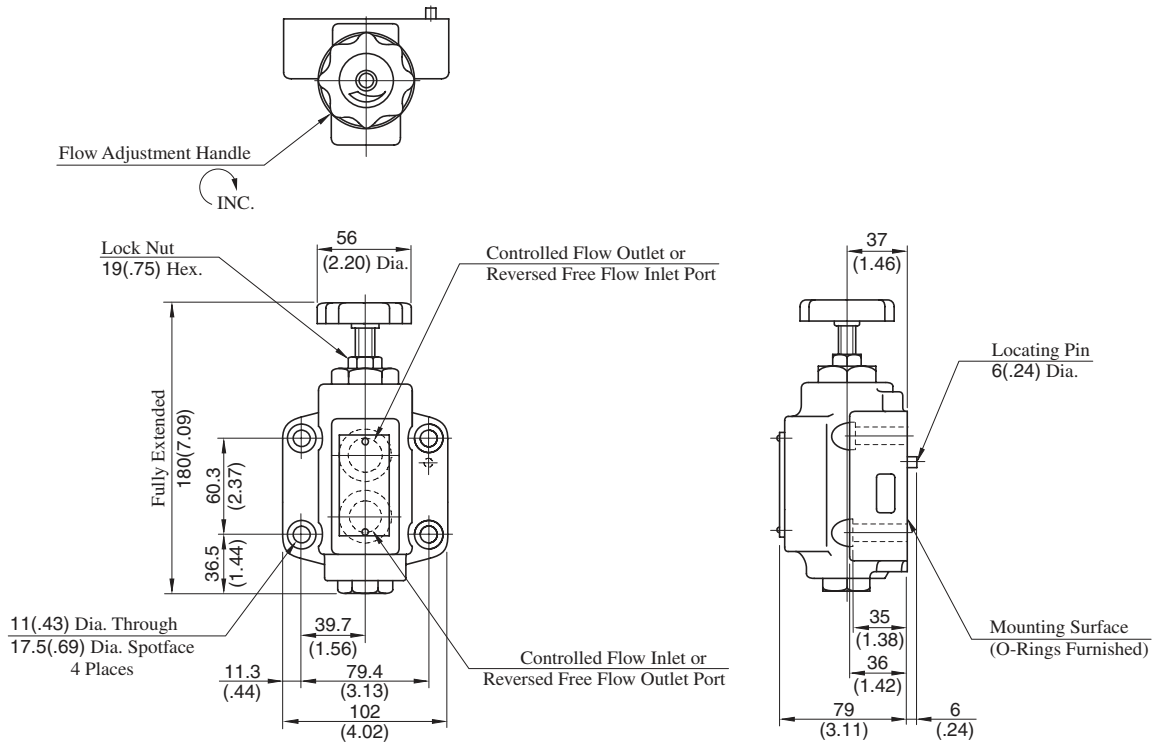

Note: For dimensions of the valve mounting surface, see the dimensional drawing (P.502) of the sub-plate used together.

SRG/SRCG-10-50/5090

Mounting surface: ISO 5781-AJ-10-2-A

**DIMENSIONS IN  
MILLIMETRES (INCHES)**

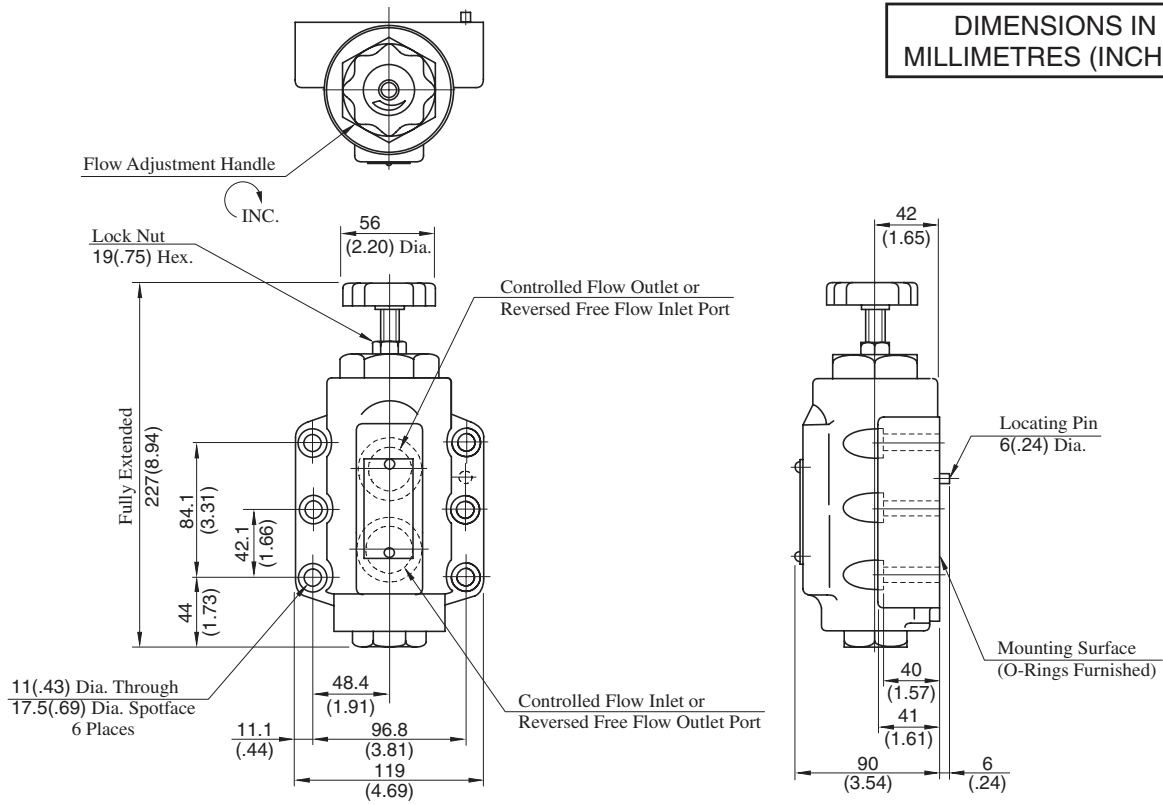

Note: For dimensions of the valve mounting surface, see the dimensional drawing (P.502) of the sub-plate used together.

## Metred Flow vs Adjustment Handle Revolutions

Hydraulic Fluid: Viscosity 30 mm<sup>2</sup>/s (141 SSU), Specific Gravity 0.850

$\Delta P$ : Differential Pressure MPa (PSI)

### SRT SRG-03, SRCT SRCG-03

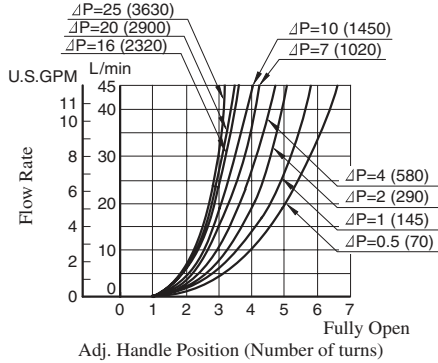

### SRT SRG-06, SRCT SRCG-06

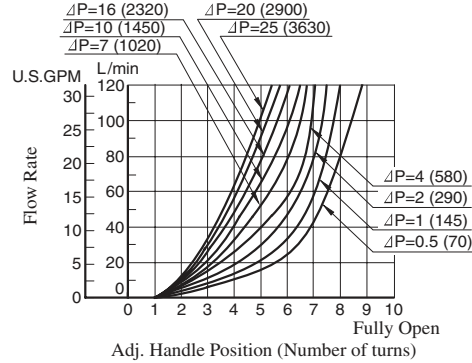

### SRT SRG-10, SRCT SRCG-10

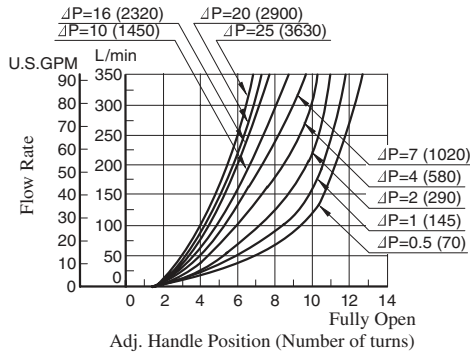

## Pressure Drop

Hydraulic Fluid: Viscosity 30 mm<sup>2</sup>/s (141 SSU), Specific Gravity 0.850

### SRT SRG-03, SRCT SRCG-03

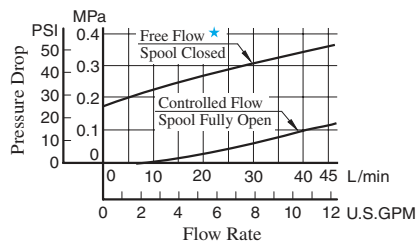

### SRT SRG-06, SRCT SRCG-06

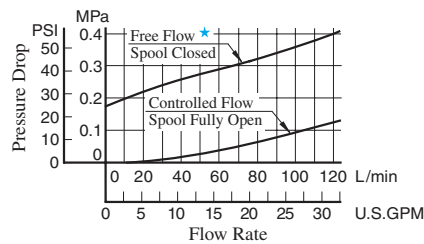

### SRT SRG-10, SRCT SRCG-10

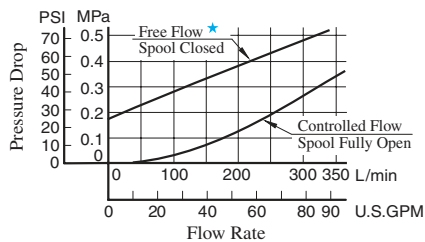

★ Applicable only for one way restrictor (Model No. SRC\*)

■ List of seals

SRT/SRCT-03-50/5080/5090  
 SRT/SRCT-06-50/5080/5090  
 SRT/SRCT-10-50/5080/5090

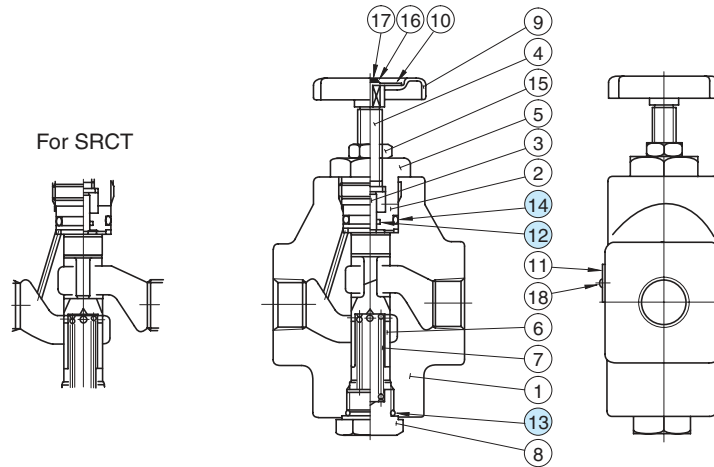

● List of Seals

Item	Name of Parts	Part Numbers			Qty.
		SRT SRCT-03	SRT SRCT-06	SRT SRCT-10	
12	O-Ring	SO-NB-P7	SO-NB-P7	SO-NB-P7	1
13	O-Ring	SO-NB-P15	SO-NB-P21	SO-NB-P29	1
14	O-Ring	SO-NB-P20	SO-NB-P22.4	SO-NB-P36	1

● List of Seal Kits

Valve Model Numbers	Seal Kit Numbers
SRT/SRCT-03	KS-SRT-03-50
SRT/SRCT-06	KS-SRT-06-50
SRT/SRCT-10	KS-SRT-10-50

Note: When ordering the seals, please specify the seal kit number from the table right.

SRG/SRCG-03-50/5090  
 SRG/SRCG-06-50/5090  
 SRG/SRCG-10-50/5090

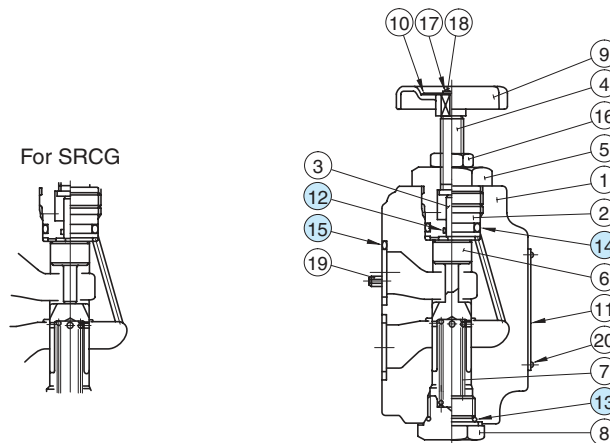

● List of Seals

Item	Name of Parts	Part Numbers			Qty.
		SRG SRCG-03	SRG SRCG-06	SRG SRCG-10	
12	O-Ring	SO-NB-P7	SO-NB-P7	SO-NB-P7	1
13	O-Ring	SO-NB-P15	SO-NB-P21	SO-NB-P29	1
14	O-Ring	SO-NB-P20	SO-NB-P22.4	SO-NB-P36	1
15	O-Ring	SO-NB-P18	SO-NB-P28	SO-NB-P32	2

● List of Seal Kits

Valve Model Numbers	Seal Kit Numbers
SRG/SRCG-03	KS-SRG-03-50
SRG/SRCG-06	KS-SRG-06-50
SRG/SRCG-10	KS-SRG-10-50

Note: When ordering the seals, please specify the seal kit number from the table right.

## Throttle Modules / Throttle and Check Modules

Used as pilot choke valves for solenoid controlled pilot operated directional valves and pilot operated directional valves.



Graphic Symbols

Valve Size	Throttle Modules		Throttle and Check Modules	
	Standard Type	With Check	Standard (Metre-out) Type	Metre-in Type
01	 P A B T TC1G-01	 P A B T TC1G-01-C	 P A B T TC2G-01	 P A B T TC2G-01-A
03	 P A B T TC1G-03	 P A B T TC1G-03-C	 P A B T TC2G-03	 P A B T TC2G-03-A

### Specifications

Model Numbers	Nominal Flow L/min (U.S.GPM)	Max. Operating Pressure MPa (PSI)	Approx. Mass kg (lbs.)
TC1G-01-40/4090	30 (7.9)	25 (3630)	0.6 (1.3)
TC2G-01-40/4090			0.65 (1.4)
TC1G-03-*-40/4090	80 (21.1)		1.6 (3.5)
TC2G-03-*-40/4090			1.8 (4.0)

### Model Number Designation

F-	TC1	G	-03	-C	-40	*
Special Seals	Series Number	Type of Mounting	Valve Size	Valve Type	Design Number	Design Standards
F: Special Seals for Phosphate Ester Type Fluids (Omit if not required)	TC1: Throttle Module	G: Gasket Mounting	01	None: Std. Type	40	None: Japanese Std. "JIS" and European Design Std. 90: N. American Design Std.
	TC2: Throttle and Check Module			None: Std. (Metre-Out) Type		
	TC1: Throttle Module	G: Gasket Mounting	03	None: Std. Type C: With Check Valve	40	
	TC2: Throttle and Check Module			None: Std. (Metre-Out) Type A: Metre-in Type		

■ Attachment

● **Mounting Bolts**

If mounting bolts are necessary, order suitable ones selected from the table below. If mounting bolts from other companies are used, their strength must be 8.8 or up ISO standards.

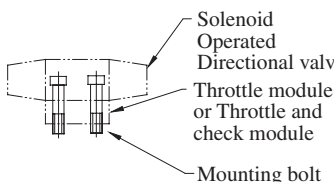
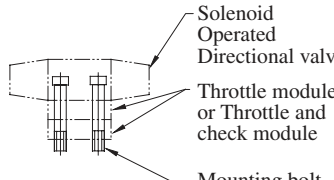
Solenoid Operated Directional Valve	Valve Model Numbers	Socket Head Cap Screw		Qty.
		Japanese Std. "JIS" & European Design Std.	N. American Design Std.	
	TC*G-01	M5 × 70 Lg.	No. 10-24 UNC × 2-3/4 Lg.	4
	TC*G-03	M6 × 70 Lg.	1/4-20 UNC × 2-3/4 Lg.	4
	TC*G-01	M5 × 95 Lg.	No. 10-24 UNC × 3-3/4 Lg.	4
	TC*G-03	M6 × 100 Lg.	1/4-20 UNC × 4 Lg.	4

■ Instructions

● **Flow adjustment**

Slacken the lock nut and turn the flow adjustment screw clockwise caused the flow rate to decrease  
After adjustment, be sure to tighten the lock nut.

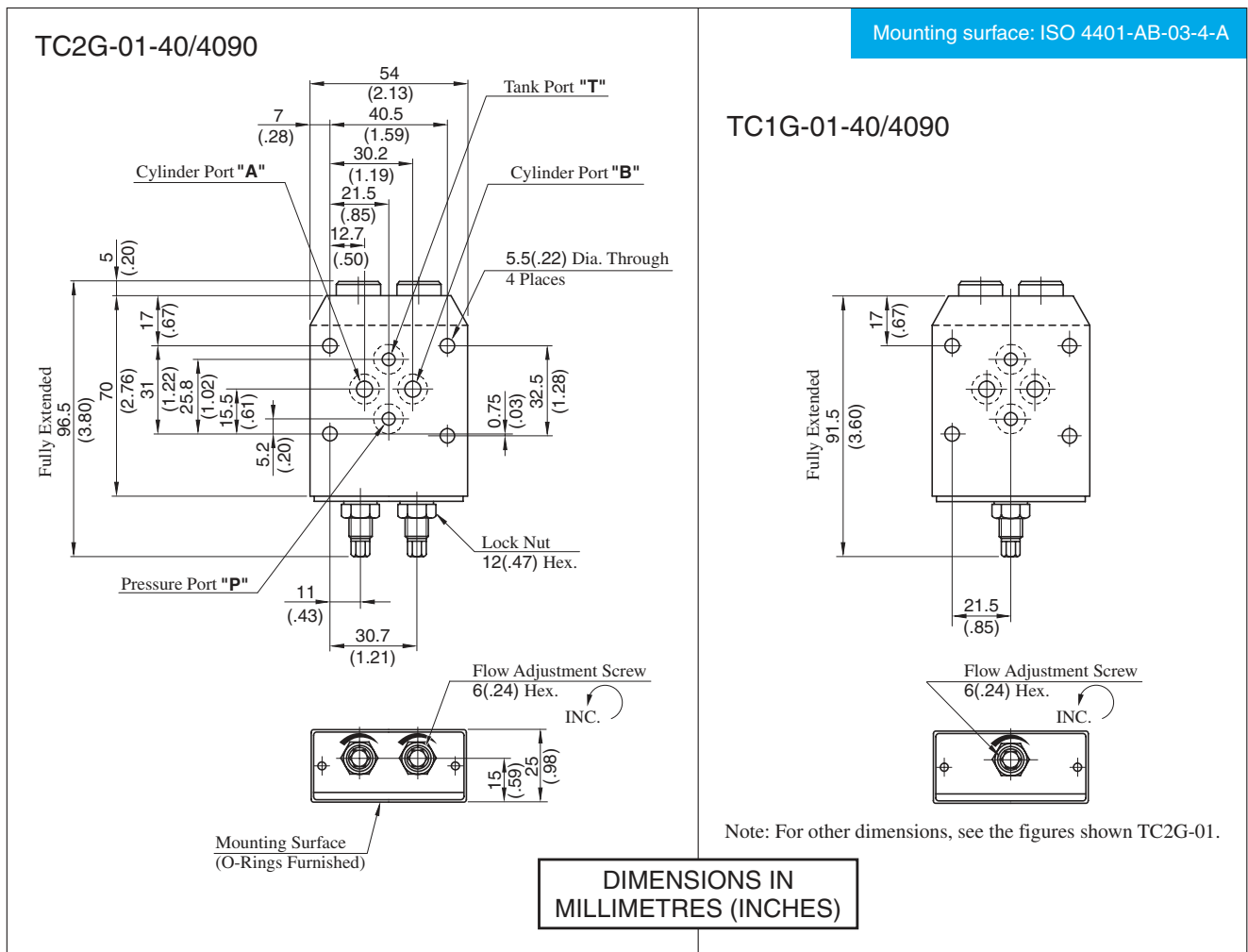



TC2G-03-40/4090  
TC2G-03-A-40/4090

Mounting surface: ISO 4401-AC-05-4-A

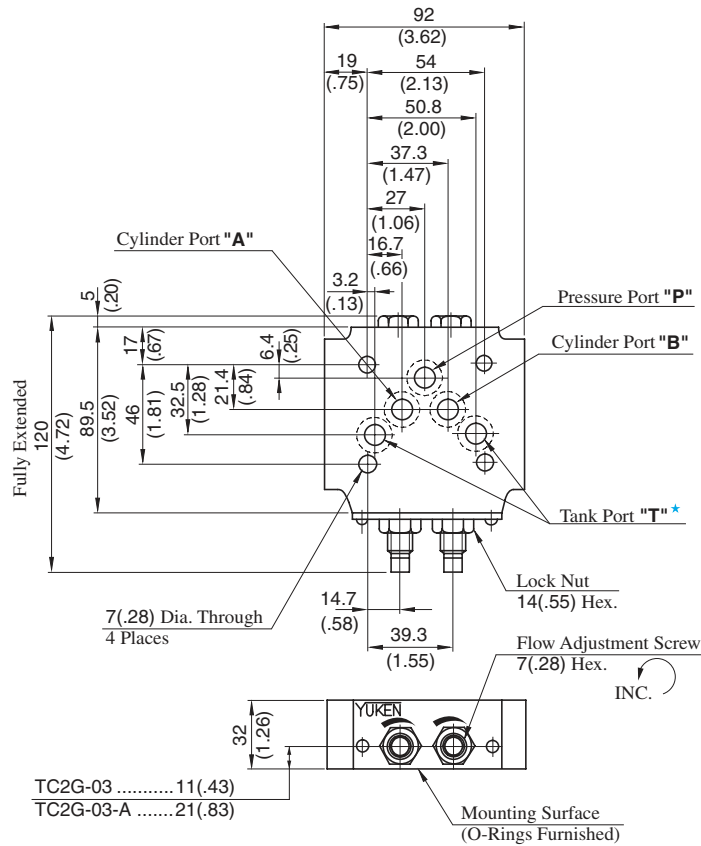

★ With standard sub-plates, the left one of the two tank ports "T" is used but either one may be used.

DIMENSIONS IN  
MILLIMETRES (INCHES)

TC1G-03-40/4090  
TC1G-03-C-40/4090

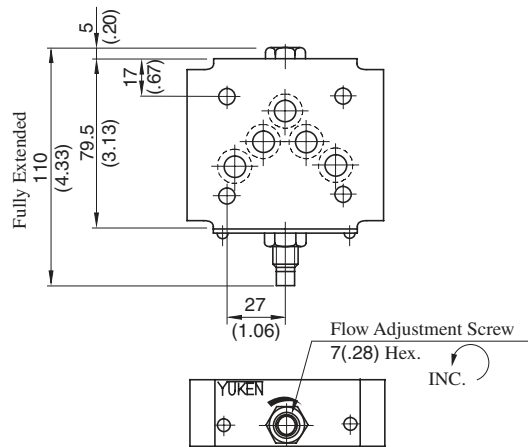

Note: For other dimensions, see the figures shown TC2G-03.

Hydraulic Fluid: Viscosity 35 mm<sup>2</sup>/s (164 SSU) , Specific Gravity 0.850

**Metred Flow vs. Adjustment Revolutions**

**Pressure Drop**

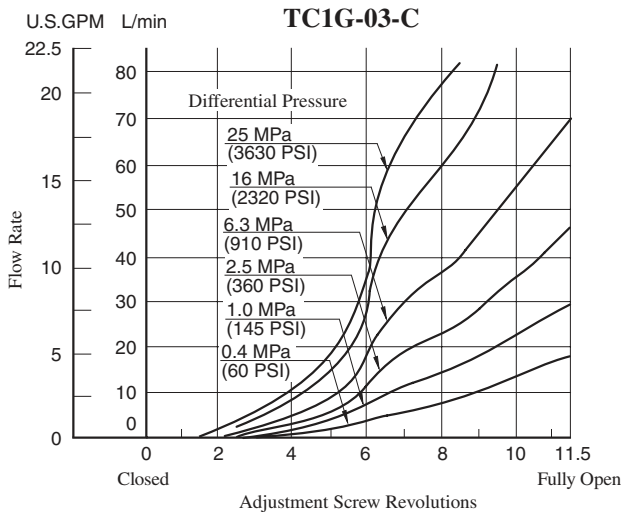
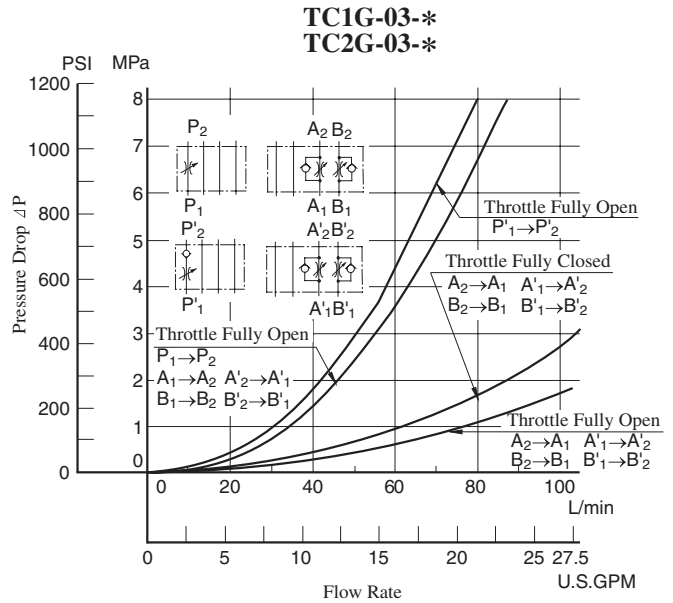
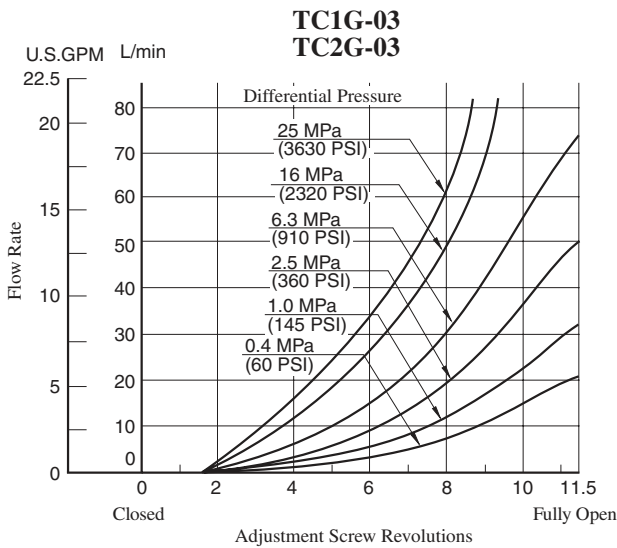
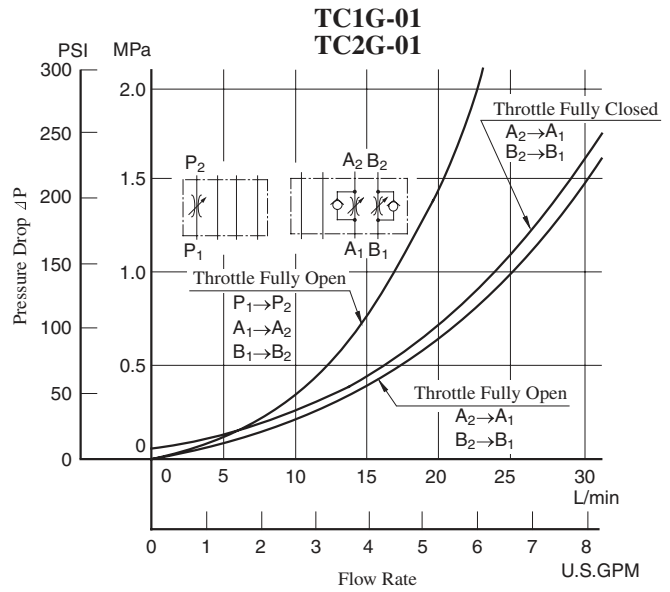
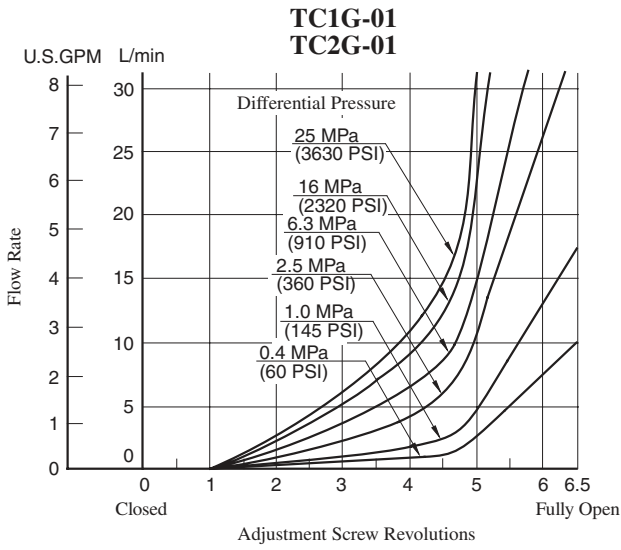

- For any other viscosity, multiply the factors in the table below.

Viscosity	mm <sup>2</sup> /s	15	20	30	40	50	60	70	80	90	100
		SSU	77	98	141	186	232	278	324	371	417
Factor		0.81	0.87	0.96	1.03	1.09	1.14	1.19	1.23	1.27	1.30

- For any other specific gravity (G'), the pressure drop (ΔP') may be obtained from the formula below.  

$$\Delta P' = \Delta P (G' / 0.850)$$

List of Seals

TC1G-01-40/4090  
TC1G-03-\*-40/4090

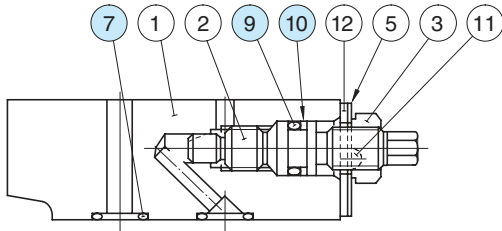

TC1G-01

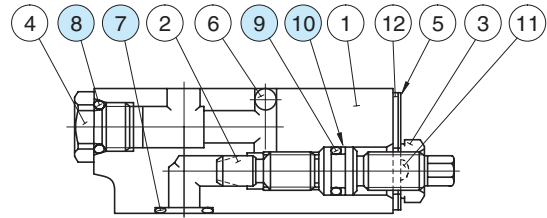

TC1G-03

List of Seals

Item	Name of Parts	Part Numbers		Qty.
		TC1G-01	TC1G-03	
7	O-Ring	SO-NB-P9	SO-NB-A014	5★
8	O-Ring	—	SO-NB-P10	1
9	O-Ring	SO-NA-P7	SO-NA-P9	1
10	Back Up Ring	SO-BB-P7	SO-BB-P9	1

★ With TC1G-01, four O-Rings, Item ⑦, are used.

Note: When ordering the seals, please specify the seal kit number from the table right

List of Seal Kits

Valve Model Numbers	Seal Kit Numbers
TC1G-01	KS-TC1G-01-40
TC1G-03	KS-TC1G-03-40
TC1G-03-C	

TC2G-01-40/4090  
TC2G-03-\*-40/4090

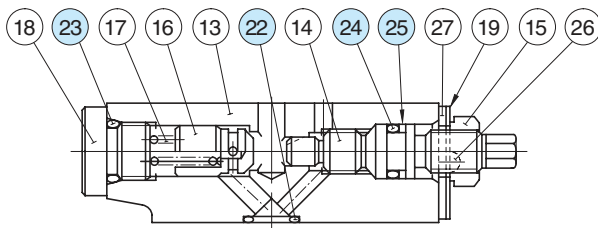

TC2G-01

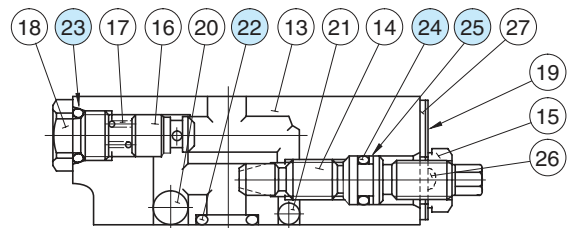

TC2G-03

List of Seals

Item	Name of Parts	Part Numbers		Qty.
		TC2G-01	TC2G-03	
22	O-Ring	SO-NB-P9	SO-NB-A014	5★
23	O-Ring	SO-NB-P10	SO-NB-P10	2
24	O-Ring	SO-NA-P7	SO-NA-P9	2
25	Back Up Ring	SO-BB-P7	SO-BB-P9	2

★ With TC2G-01, four O-Rings, Item ②, are used.

Note: When ordering the seals, please specify the seal kit number from the table right

List of Seal Kits

Valve Model Numbers	Seal Kit Numbers
TC2G-01	KS-TC2G-01-40
TC2G-03	KS-TC2G-03-40
TC2G-03-A	

## Deceleration Valves / Deceleration and Check Valves

These valves are available either with or without an integral check valve which allows free reverse flow. Flow rate through the valve is regulated by the movement of the spool, which is operated by a cam. When the spool is depressed, the flow is decreased in Normally Open type valves and increased in Normally Closed type valves. Their principal use is to control the speed of actuators in machine tools and similar applications.

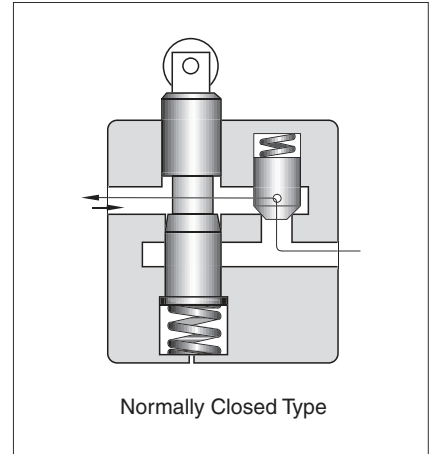
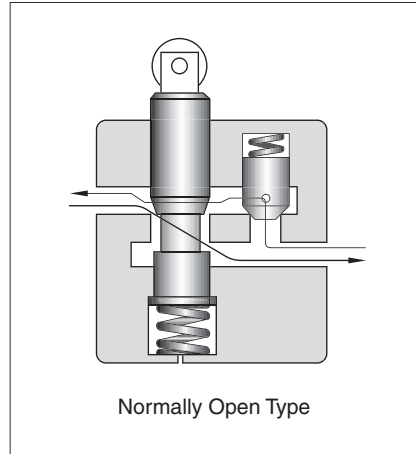

### Specifications

Model Numbers		Max. Flow L/min (U.S.GPM)	Max. Operating Pressure MPa (PSI)	Approx. Mass kg (lbs.)	
Threaded Connection	Sub-plate Mounting			Z*T	Z*G
ZT/ZCT-03-*-*-22/2280/2290	ZG/ZCG-03-*-*-22/2290	30 (7.9)	21 (3050)	4.3 (9.5)	4.3 (9.5)
ZT/ZCT-06-*-*-22/2280/2290	ZG/ZCG-06-*-*-22/2290	80 (21.1)		8.7 (19.2)	8.7 (19.2)
ZT/ZCT-10-*-*-22/2280/2290	ZG/ZCG-10-*-*-22/2290	200 (52.8)		17 (37.5)	17 (37.5)

### Model Number Designation

F-	ZC	T	-03	-T	-C	-22	*		
Special Seals	Series Number	Type of Mounting	Valve Size	With Adjustable Needle Valve for By-Pass Line	Spool Type	Design Number	Design Standards		
<b>F:</b> Special Seals for Phosphate Ester Type Fluids (Omit if not required)	<b>Z:</b> Deceleration Valve	<b>T:</b> Threaded Connection	03	<b>T:</b> With Adjustable Needle Valve (Omit if not required)	<b>None:</b> Normally Open Type	22	<b>None:</b> Japanese Std. "JIS" <b>80:</b> European Design Std. <b>90:</b> N. American Design Std.		
			06			22			
			10			22			
		<b>G:</b> Sub-plate Mounting	03			<b>C:</b> Normally Closed Type	22	<b>None:</b> Japanese Std. "JIS" & European Design Std. <b>90:</b> N. American Design Std.	
			06				22		
			10				22		
	<b>ZC:</b> Deceleration and Check Valve	<b>T:</b> Threaded Connection	<b>T:</b> With Adjustable Needle Valve (Omit if not required)	03	<b>None:</b> Normally Open Type	<b>C:</b> Normally Closed Type	22	<b>None:</b> Japanese Std. "JIS" <b>80:</b> European Design Std. <b>90:</b> N. American Design Std.	
				06			22		
				10			22		
		<b>G:</b> Sub-plate Mounting		03			<b>C:</b> Normally Closed Type	22	<b>None:</b> Japanese Std. "JIS" & European Design Std. <b>90:</b> N. American Design Std.
				06				22	
				10				22	

### Graphic Symbols

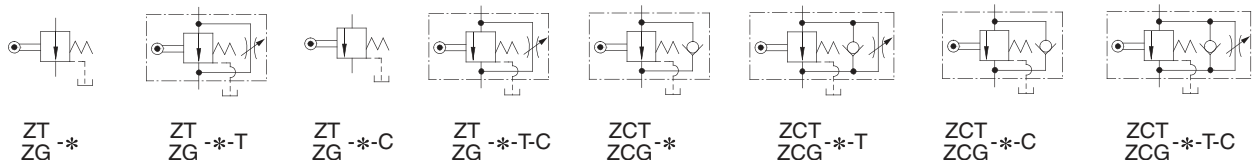

## Instructions

### Force to Depress Spool

Model Numbers	Force N (lbs.)
ZY/ZG ZCT/ZCG-03	150 (337)
ZY/ZG ZCT/ZCG-06	270 (607)
ZY/ZG ZCT/ZCG-10	400 (899)

### Total Leakage at Spool Fully Closed [Viscosity:20 mm<sup>2</sup>/s (98 SSU)]

Model Numbers	Total Leakage cm <sup>3</sup> /min (cu.in./min)				
	Pressure MPa (PSI)				
	1 (145)	2 (290)	5 (730)	10 (1450)	21 (3050)
ZY/ZG ZCT/ZCG-03	9 (.55)	18 (1.10)	44 (2.7)	88 (5.4)	185 (11.3)
ZY/ZG ZCT/ZCG-06	9 (.55)	17 (1.04)	43 (2.6)	86 (5.2)	180 (11.0)
ZY/ZG ZCT/ZCG-10	10 (.61)	20 (1.22)	49 (3.0)	98 (6.0)	205 (12.5)

### Drain Port Back Pressure

Limit the drain port back pressure to 0.1 MPa (15 PSI).

In addition, connect the drain pipe independently and directly to the tank.

## Attachment

### Mounting Bolts

Valve Model Numbers	Socket Head Cap Screw		Qty.
	Japanese Std. "JIS" and European Design Std.	N. American Design Std.	
ZG/ZCG-03	M8 × 75 Lg.	5/16-18 UNC × 3 Lg.	4
ZG/ZCG-06	M10 × 100 Lg.	3/8-16 UNC × 4 Lg.	4
ZG/ZCG-10	M12 × 120 Lg.	1/2-13 UNC × 4-3/4 Lg.	4

## Option

### Bypass throttle valves

To allow a metred flow between ports even when the flow is stopped by the spool.

## Sub-plate

Valve Model Numbers	Japanese Standard "JIS"		European Design Standard		N.American Design Standard		Approx. Mass kg (lbs.)
	Sub-plate Model No.	Thread Size	Sub-plate Model No.	Thread Size	Sub-plate Model No.	Thread Size	
ZG/ZCG-03	ZGM-03-21	Rc 3/8	ZGM-03-2180	3/8 BSP.F	ZGM-03-2190	3/8 NPT	2 (4.4)
ZG/ZCG-06	ZGM-06-21	Rc 3/4	ZGM-06-2180	3/4 BSP.F	ZGM-06-2190	3/4 NPT	3.8 (8.4)
ZG/ZCG-10	ZGM-10-21	Rc 1-1/4	ZGM-10-2180	1-1/4 BSP.F	ZGM-10-2190	1-1/4 NPT	9 (19.8)

- Sub-plates are available. Specify the sub-plate model number from the table above. When sub-plates are not used, the mounting surface should have a good machined finish.

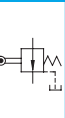

ZT/ZCT-03-\*-22/2280/2290  
 ZT/ZCT-06-\*-22/2280/2290  
 ZT/ZCT-10-\*-22/2280/2290

**DIMENSIONS IN  
 MILLIMETRES (INCHES)**

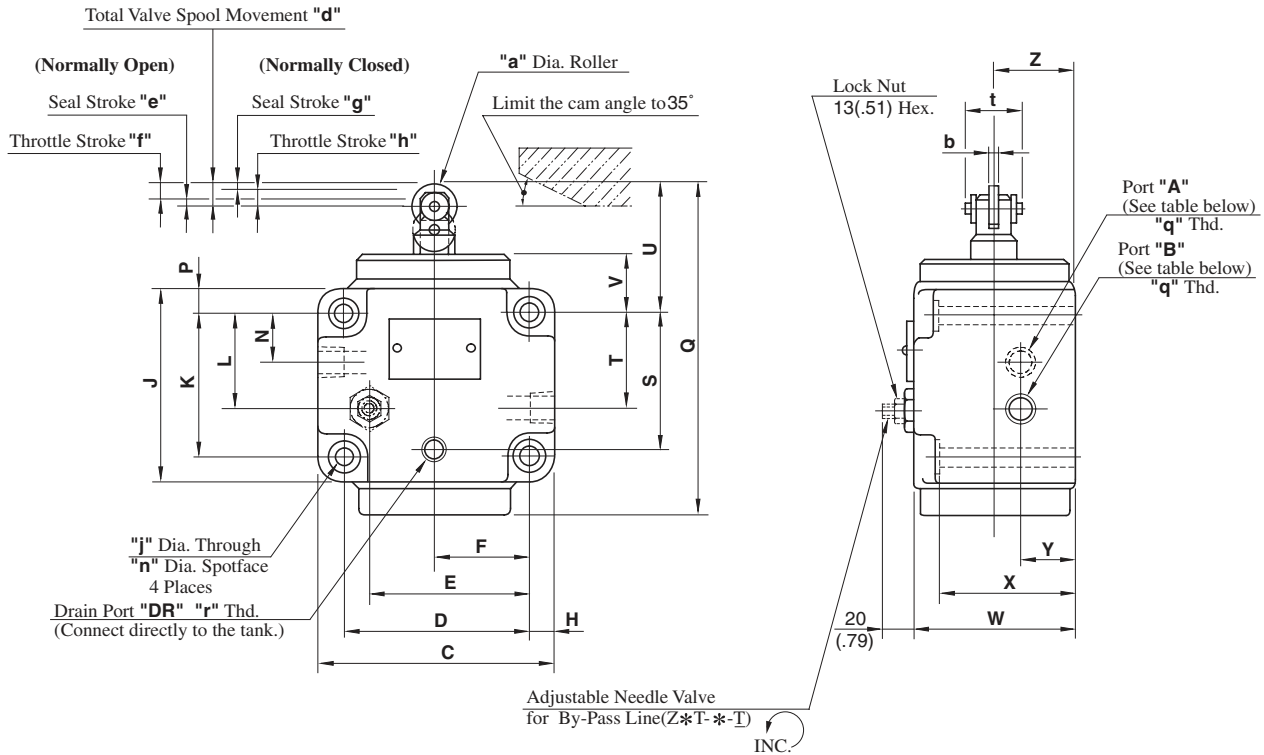

Model Numbers	Port "A"	Port "B"
ZT-*	Controlled flow inlet	Controlled flow outlet
ZCT-*	Controlled flow inlet or Reversed free flow outlet	Controlled flow outlet or Reversed free flow inlet

Model Numbers	"q" Thd.	"r" Thd.
ZT/ZCT-03-*-22	Rc 3/8	Rc 1/4
ZT/ZCT-03-*-2280	3/8 BSP.F	1/4 BSP.F
ZT/ZCT-03-*-2290	3/8 NPT	1/4 NPT
ZT/ZCT-06-*-22	Rc 3/4	Rc 1/4
ZT/ZCT-06-*-2280	3/4 BSP.F	1/4 BSP.F
ZT/ZCT-06-*-2290	3/4 NPT	1/4 NPT
ZT/ZCT-10-*-22	Rc 1-1/4	Rc 1/4
ZT/ZCT-10-*-2280	1-1/4 BSP.F	1/4 BSP.F
ZT/ZCT-10-*-2290	1-1/4 NPT	1/4 NPT

Model Numbers	Dimensions mm (Inches)															
	C	D	E	F	H	J	K	L	N	P	Q	S	T	U	V	W
ZT/ZCT-03	102 (4.02)	80 (3.15)	66 (2.60)	40 (1.57)	11 (.43)	82 (3.23)	60 (2.36)	41 (1.61)	20 (.79)	11 (.43)	141 (5.55)	58 (2.28)	40 (1.57)	56 (2.20)	25 (.98)	70 (2.76)
ZT/ZCT-06	120 (4.72)	98 (3.86)	82 (3.23)	49 (1.93)	11 (.43)	106 (4.17)	84 (3.31)	57 (2.24)	32 (1.26)	11 (.43)	176 (6.93)	81 (3.19)	57 (2.24)	65 (2.56)	27 (1.06)	95 (3.74)
ZT/ZCT-10	160 (6.30)	132 (5.20)	103 (4.06)	66 (2.60)	14 (.55)	140 (5.51)	112 (4.41)	75 (2.95)	40 (1.57)	14 (.55)	224 (8.82)	106 (4.17)	75 (2.95)	80 (3.15)	32 (1.26)	110 (4.33)

Model Numbers	Dimensions mm (Inches)												
	X	Y	Z	a	b	d	e	f	g	h	j	n	t
ZT/ZCT-03	60 (2.36)	25 (.98)	35 (1.38)	18 (.71)	6 (.24)	10 (.39)	2 (.08)	8 (.31)	2 (.08)	8 (.31)	8.8 (.35)	14 (.55)	24.5 (.96)
ZT/ZCT-06	85 (3.35)	32 (1.26)	50 (1.97)	22 (.87)	8 (.31)	13 (.51)	3 (.12)	10 (.39)	3 (.12)	10 (.39)	11 (.43)	17.5 (.69)	29 (1.14)
ZT/ZCT-10	96 (3.78)	40 (1.57)	55 (2.17)	28 (1.10)	10 (.39)	18 (.71)	3 (.12)	15 (.59)	3 (.12)	15 (.59)	13.5 (.53)	21 (.83)	34 (1.34)

ZG/ZCG-03-\*-22/2290  
 ZG/ZCG-06-\*-22/2290  
 ZG/ZCG-10-\*-22/2290

**DIMENSIONS IN  
 MILLIMETRES (INCHES)**

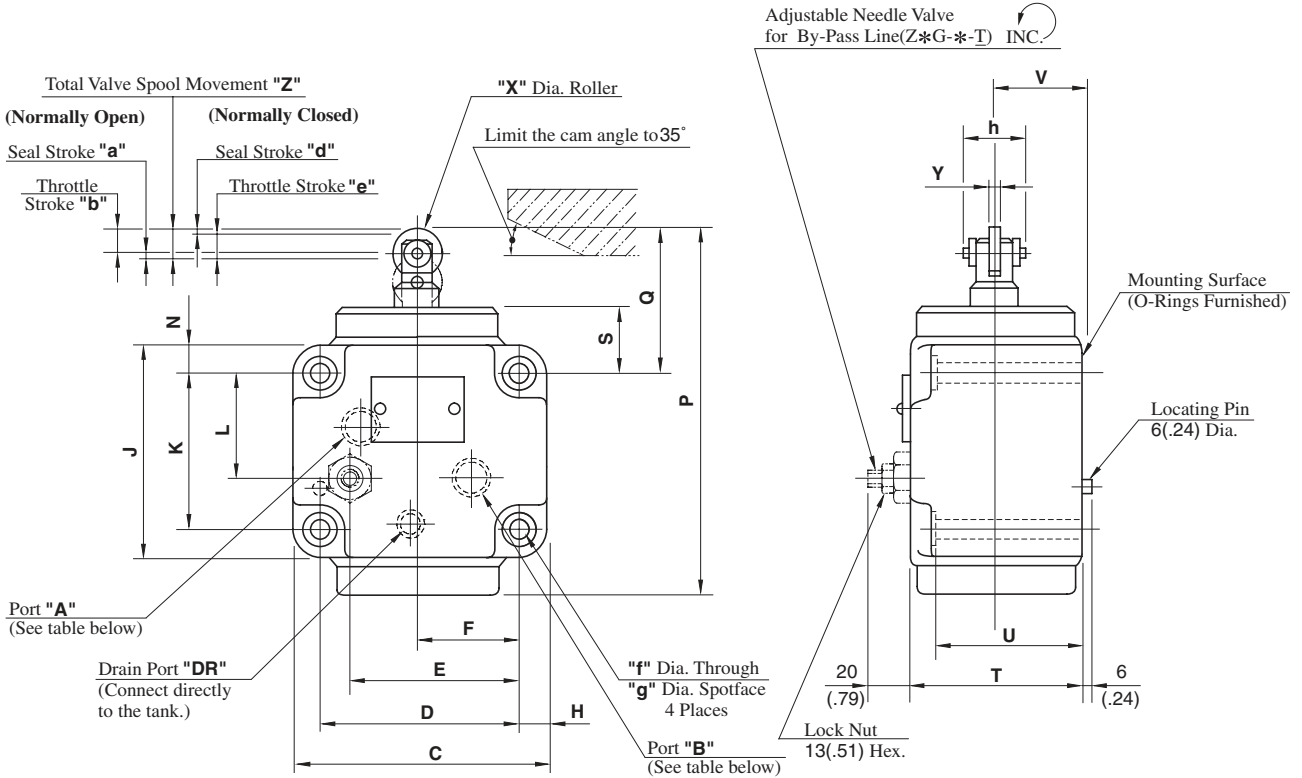

Model Numbers	Port "A"	Port "B"
ZG-*	Controlled flow inlet	Controlled flow outlet
ZCG-*	Controlled flow inlet or Reversed free flow outlet	Controlled flow outlet or Reversed free flow inlet

Model Numbers	Dimensions mm (Inches)												
	C	D	E	F	H	J	K	L	N	P	Q	S	T
ZG/ZCG-03	102 (4.02)	80 (3.15)	66 (2.60)	40 (1.57)	11 (.43)	82 (3.23)	60 (2.36)	41 (1.61)	11 (.43)	141 (5.55)	56 (2.20)	25 (.98)	70 (2.76)
ZG/ZCG-06	120 (4.72)	98 (3.86)	82 (3.23)	49 (1.93)	11 (.43)	106 (4.17)	84 (3.31)	57 (2.24)	11 (.43)	176 (6.93)	65 (2.56)	27 (1.06)	95 (3.74)
ZG/ZCG-10	160 (6.30)	132 (5.20)	103 (4.06)	66 (2.60)	14 (.55)	140 (5.51)	112 (4.41)	75 (2.95)	14 (.55)	224 (8.82)	80 (3.15)	32 (1.26)	110 (4.33)

Model Numbers	Dimensions mm (Inches)											
	U	V	X	Y	Z	a	b	d	e	f	g	h
ZG/ZCG-03	60 (2.36)	35 (1.38)	18 (.71)	6 (.24)	10 (.39)	2 (.08)	8 (.31)	2 (.08)	8 (.31)	8.8 (.35)	14 (.55)	24.5 (.96)
ZG/ZCG-06	85 (3.35)	50 (1.97)	22 (.87)	8 (.31)	13 (.51)	3 (.12)	10 (.39)	3 (.12)	10 (.39)	11 (.43)	17.5 (.69)	29 (1.14)
ZG/ZCG-10	96 (3.78)	55 (2.17)	28 (1.10)	10 (.39)	18 (.71)	3 (.12)	15 (.59)	3 (.12)	15 (.59)	13.5 (.53)	21 (.83)	34 (1.34)

**D**  
 Deceleration Valves  
 Deceleration and Check Valves

ZGM-03-21/2180/2190  
 ZGM-06-21/2180/2190  
 ZGM-10-21/2180/2190

**DIMENSIONS IN  
 MILLIMETRES (INCHES)**

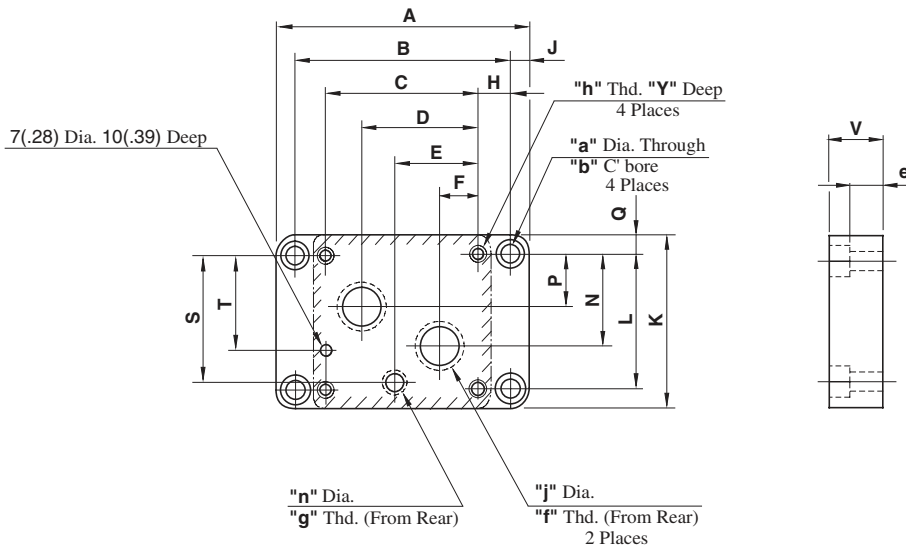

Model Numbers	Thd. Size			mm (Inches)	
	"f" Thd.	"g" Thd.	"h" Thd.	j	n
ZGM-03-21	Rc 3/8	Rc 1/4	M8	14 (.55)	6.2 (.24)
ZGM-03-2180	3/8 BSPF	1/4 BSPF		15 (.59)	
ZGM-03-2190	3/8 NPT	1/4 NPT		14 (.55)	
ZGM-06-21	Rc 3/4	Rc 1/4	M10	23 (.91)	11 (.43)
ZGM-06-2180	3/4 BSPF	1/4 BSPF		24.5 (.96)	
ZGM-06-2190	3/4 NPT	1/4 NPT		23 (.91)	
ZGM-10-21	Rc 1-1/4	Rc 1/4	M12	29 (1.14)	11 (.43)
ZGM-10-2180	1-1/4 BSPF	1/4 BSPF			11.7 (.46)
ZGM-10-2190	1-1/4 NPT	1/4 NPT			11 (.43)

Model Numbers	Dimensions mm (Inches)													
	A	B	C	D	E	F	H	J	K	L	N	P	Q	S
ZGM-03	146 (5.75)	124 (4.88)	80 (3.15)	60 (2.36)	42 (1.65)	20 (.79)	22 (.87)	11 (.43)	85 (3.35)	60 (2.36)	40 (1.57)	20 (.79)	12.5 (.49)	58 (2.28)
ZGM-06	160 (6.30)	138 (5.43)	98 (3.86)	74 (2.91)	53 (2.09)	24 (.94)	20 (.79)	11 (.43)	108 (4.25)	84 (3.31)	57 (2.24)	32 (1.26)	12 (.47)	81 (3.19)
ZGM-10	218 (8.58)	190 (7.48)	132 (5.20)	98 (3.86)	70 (2.76)	34 (1.34)	29 (1.14)	14 (.55)	140 (5.51)	112 (4.41)	75 (2.95)	40 (1.57)	14 (.55)	106 (4.17)

Model Numbers	Dimensions mm (Inches)					
	T	V	Y	a	b	e
ZGM-03	44 (1.73)	26 (1.02)	18 (.71)	11 (.43)	17.5 (.69)	15.2 (.60)
ZGM-06	60 (2.36)	35 (1.38)	18 (.71)	11 (.43)	17.5 (.69)	24.2 (.95)
ZGM-10	87 (3.43)	45 (1.77)	25 (.98)	14 (.55)	21 (.83)	31.5 (1.24)



Hydraulic Fluid: Viscosity 20 mm<sup>2</sup>/s (98 SSU), Specific Gravity 0.850

## Pressure Drop for Reversed Free Flow

**ZCT-03**  
**ZCG-03**

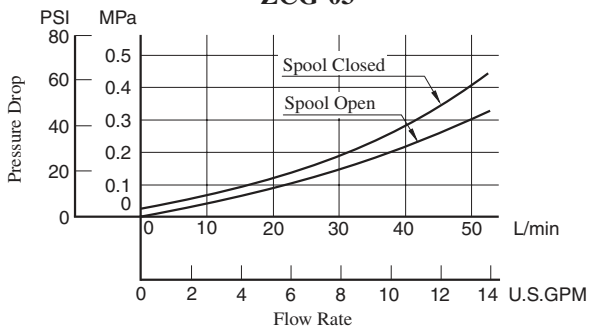

**ZCT-06**  
**ZCG-06**

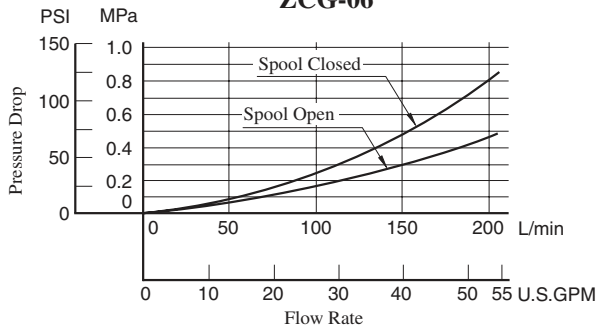

**ZCT-10**  
**ZCG-10**

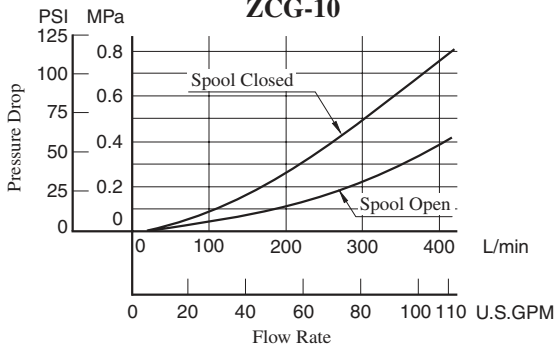

## Metred Flow vs. Spool Depression

**Z\*T-03**  
**Z\*G-03**

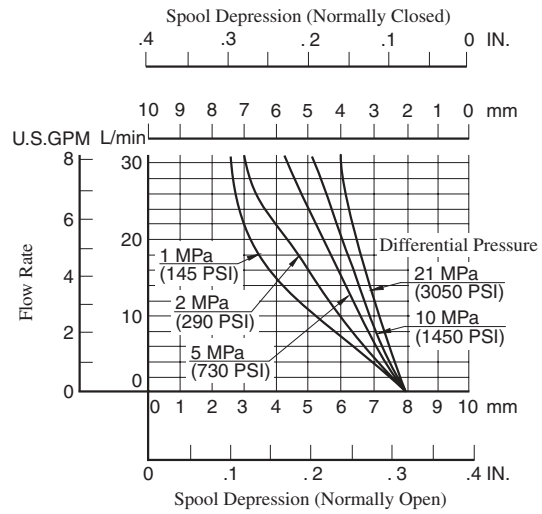

**Z\*T-06**  
**Z\*G-06**

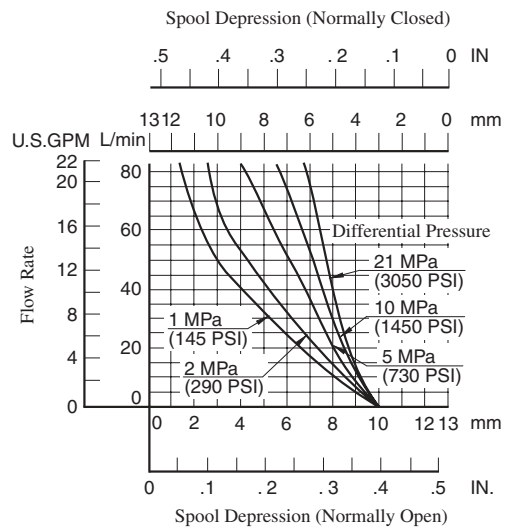

**Z\*T-10**  
**Z\*G-10**

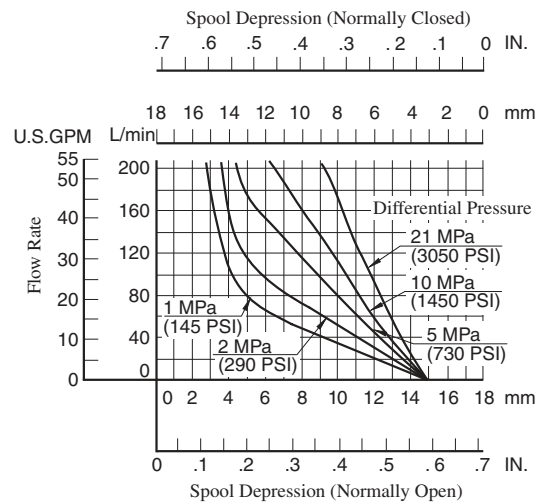

Hydraulic Fluid: Viscosity 20 mm<sup>2</sup>/s (98 SSU) , Specific Gravity 0.850

■ Metred Flow for Needle Valve

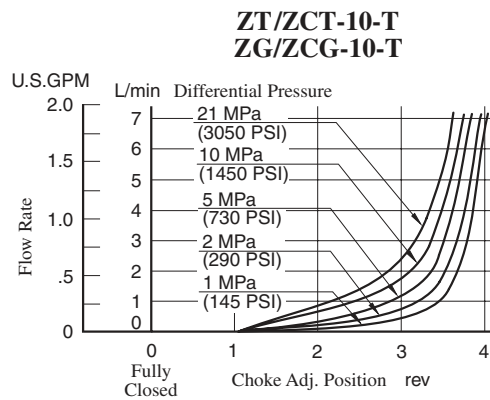
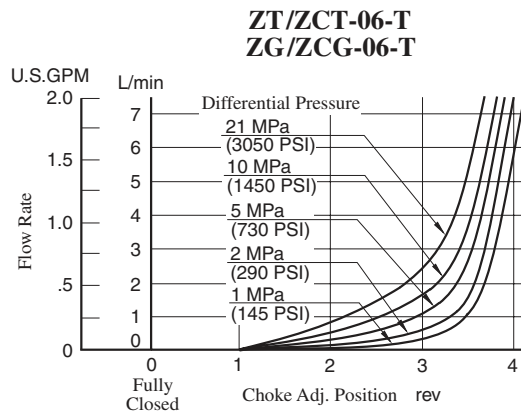
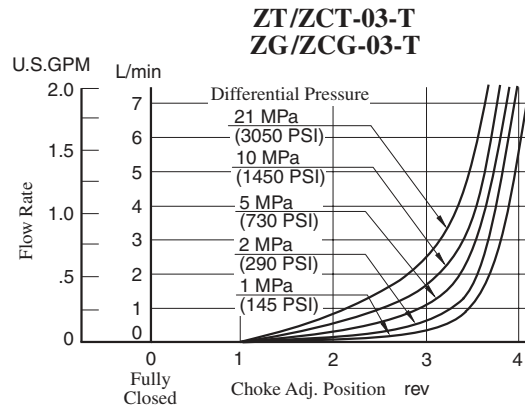

## List of Seals

ZT/ZCT-03-\*-22/2280/2290  
 ZT/ZCT-06-\*-22/2280/2290  
 ZT/ZCT-10-\*-22/2280/2290

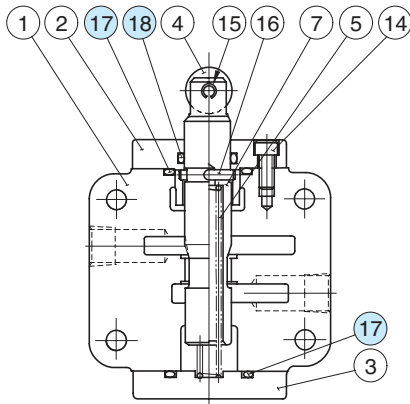

With Check Valve  
(ZCT-\*)

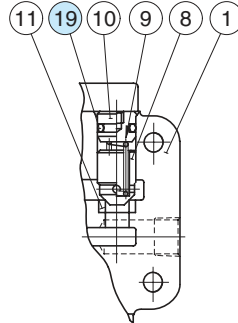

With Adjustable Needle Valve  
for By-Pass Line

(ZT  
ZCT-\*T)

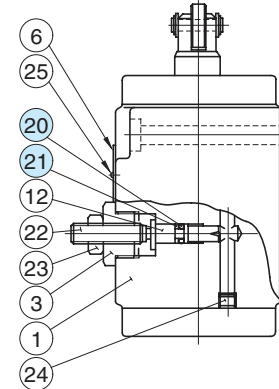

### List of Seals

Item	Name of Parts	Part Numbers			Qty.
		ZT ZCT-03	ZT ZCT-06	ZT ZCT-10	
17	O-Ring	SO-NB-P32	SO-NB-P36	SO-NB-P49	2
18	O-Ring	SO-NA-P20	SO-NA-P25	SO-NA-P32	1
19	O-Ring	SO-NB-P12	SO-NB-P18	SO-NB-P22A	1
20	O-Ring	SO-NA-P5	SO-NA-P5	SO-NA-P5	1
21	Back Up Ring	SO-BB-P5	SO-BB-P5	SO-BB-P5	1

Note: When ordering the seals, please specify the seal kit number from the table right.

### List of Seal Kits

Valve Model Numbers	Seal Kit Numbers
ZT-03	KS-ZT-03-22
ZT-06	KS-ZT-06-22
ZT-10	KS-ZT-10-22
ZCT-03	KS-ZCT-03-22
ZCT-06	KS-ZCT-06-22
ZCT-10	KS-ZCT-10-22

ZG/ZCG-03-\*-22/2290  
 ZG/ZCG-06-\*-22/2290  
 ZG/ZCG-10-\*-22/2290

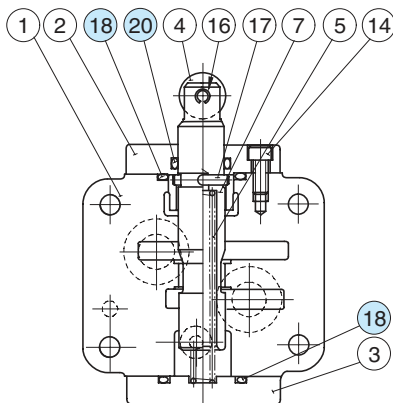

With Check Valve  
(ZCG-\*)

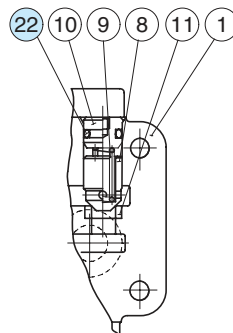

With Adjustable Needle Valve  
for By-Pass Line

(ZG  
ZCG-\*T)

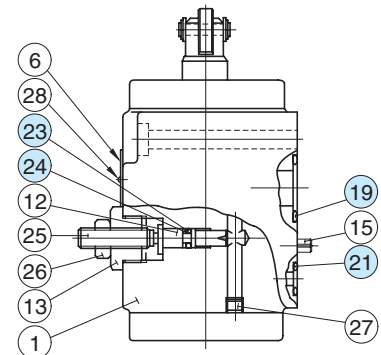

### List of Seals

Item	Name of Parts	Part Numbers			Qty.
		ZG ZCG-03	ZG ZCG-06	ZG ZCG-10	
18	O-Ring	SO-NB-P32	SO-NB-P36	SO-NB-P49	2
19	O-Ring	SO-NB-P18	SO-NB-P28	SO-NB-P32	2
20	O-Ring	SO-NA-P20	SO-NA-P25	SO-NA-P32	1
21	O-Ring	SO-NB-P9	SO-NB-P14	SO-NB-P14	1
22	O-Ring	SO-NB-P12	SO-NB-P18	SO-NB-P22A	1
23	O-Ring	SO-NA-P5	SO-NA-P5	SO-NA-P5	1
24	Back Up Ring	SO-BB-P5	SO-BB-P5	SO-BB-P5	1

Note: When ordering the seals, please specify the seal kit number from the table right.

### List of Seal Kits

Valve Model Numbers	Seal Kit Numbers
ZG-03	KS-ZG-03-22
ZG-06	KS-ZG-06-22
ZG-10	KS-ZG-10-22
ZCG-03	KS-ZCG-03-22
ZCG-06	KS-ZCG-06-22
ZCG-10	KS-ZCG-10-22

## Feed Control Valves

These valves are the combination of flow control valve, a deceleration valve and a check valve and used mainly for controlling rapid traverse and feed cycles machine tools. Switching from rapid traverse to feed is made by a cam operation, and fine feed control is accomplished by dial rotation regardless of pressure and oil temperature variation. Rapid return is free of cam actuation.

### Specifications

Model Numbers	Max. Flow <sup>★1</sup> L/min (U.S.GPM)	Metred Flow Range L/min (U.S.GPM)		Max. Reversed Free Flow L/min (U.S.GPM)	Max. Operating Pressure MPa (PSI)	Approx. Mass kg (lbs.)
		Feed	Fine Feed			
UCF1G-01-4-A-*-11*	16 [12] (4.2 [3.2])	0.03-4 (.008-1.06)	—	20 (5.3)	14 (2030)	1.6 (3.5)
UCF1G-01-4-B-*-11*	12 [8] (3.2 [2.1])					
UCF1G-01-4-C-*-11*	8 [4] (2.1 [1.06])					
UCF1G-01-8-A-*-11*	20 [12] (5.3 [3.2])	0.03-8 (.008-2.1)	—	40 (10.6)	14 (2030)	2.6 (5.7)
UCF1G-01-8-B-*-11*	16 [8] (4.2 [2.1])					
UCF1G-01-8-C-*-11*	12 [4] (3.2 [1.06])					
UCF1G-03-4-*-10*	40 [40] (10.6 [10.6])	0.05-4 (.013-1.06)	—	40 (10.6)	14 (2030)	2.6 (5.7)
UCF1G-03-8-*-10*		0.05-8 (.013-2.1)	—			
UCF2G-03-4-*-10*	40 [40] (10.6 [10.6])	0.1-4 (.026-1.06)	0.05-4 (.013-1.06)	40 (10.6)	14 (2030)	2.7 (6.0)
UCF2G-03-8-*-10*		0.1-8 (.026-2.1)	0.05-4 (.013-1.06)			
UCF1G-04-30-30*	80 [40] (21.1 [10.6])	0.1-22 (.026-5.8)	—	80 (21.1)	14 (2030)	6.5 (14.3)
UCF2G-04-30-30*		0.1-22 (.026-5.8)	0.1-17 (.026-4.5)			9.2 (20.3)

★ 1. The maximum flow rates are values with the deceleration valve and the flow control valve fully open. The values in [ ] are maximum flow rates with the deceleration valve fully open and the flow control valve fully closed.

★ 2. The values in { } are for pressures above 7 MPa (1020 PSI).

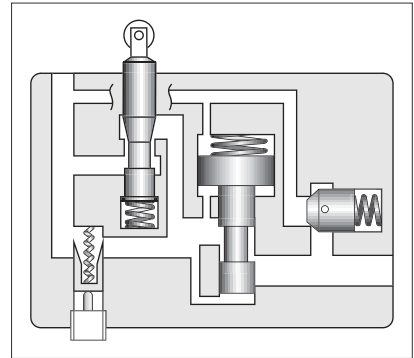
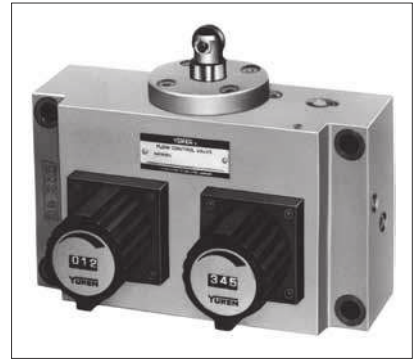

### Model Number Designation

F-	UCF1	G	-01	-4	-A	-E	-11	*
Special Seals	Series Number	Type of Mounting	Valve Size	Nominal Metred Flow L/min (U.S.GPM)	Deceleration Valve Max. Flow L/min (U.S.GPM)	Drain Connection	Design Number	Design Standards
F-: Special Seals for Phosphate Ester Type Fluids (Omit if not required)	UCF1: Single Feed Control	G: Gasket Mounting	01	4: 4 (1.06) 8: 8 (2.1)	A: 12 (3.2) B: 8 (2.1) C: 4 (1.06)	None: Internal Drain E: External Drain	11	Refer to ★
			03	4: 4 (1.06) 8: 8 (2.1)	—	10		
			04	30:30 (7.9)	—	30		
	UCF2: Double Feed Control	G: Gasket Mounting	03	4: 4 (1.06) 8: 8 (2.1)	—	None: Internal Drain E: External Drain	10	
			04	30:30 (7.9)	—	None: External Drain	30	

★ Design Standards: None. . . . . Japanese Standard "JIS" and European Design Standard 90. . . . . N. American Design Standard

## Graphic Symbols

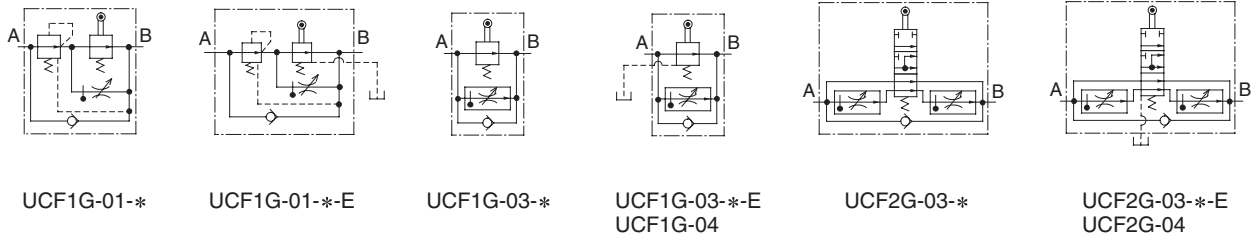

### Attachment

#### Mounting Bolts

Valve Model Numbers	Socket Head Cap Screw		Qty.
	Japanese Std. "JIS" & European Design Std.	N. American Design Std.	
UCF1G-01	M6 × 55 Lg.	1/4-20 UNC × 2-1/4 Lg.	4
UCF1G-03	M6 × 55 Lg.	1/4-20 UNC × 2-1/4 Lg.	4
UCF2G-03	M6 × 55 Lg.	1/4-20 UNC × 2-1/4 Lg.	4
UCF1G-04	M10 × 70 Lg.	3/8-16 UNC × 2-3/4 Lg.	4
UCF2G-04	M10 × 70 Lg.	3/8-16 UNC × 2-3/4 Lg.	4

### Instructions

#### Allowable pressures at controlled flow outlet

If internal drain types of UCF1G-01 or 03 or UCF2G-03 are used, use them in metre-out circuits in order to limit the valve outlet pressure to the valves shown below. In addition, external drain types can also be used in metre-in circuits.

Model Numbers		Allowable Outlet Port Back Pres. MPa (PSI)
Internal Drain Type	UCF1G-01-*	0.3 (44)
	UCF1G-03-*	
	UCF2G-03-*	
External Drain Type	UCF1G-01-*-E	14 (2030)
	UCF1G-03-*-E	
	UCF1G-04	
	UCF2G-03-*-E UCF2G-04	

#### Minimum required pressure difference

The minimum pressure differential between inlet and outlet port is required to obtain the optimum pressure compensation. It varies accordingly to the flow rate to be set. For details, refer to the performance curve.

#### Spool push down level

Limit the spool push down level within the allowable maximum stroke range shown in the installation drawings.

#### Allowable drain port back pressure

Limit to 0.1 MPa (15 PSI).

In addition, connect the drain pipe independently and directly to the tank. (This applies only to external drain types.)

#### Required Force for Spool Push Down

Model Numbers	Drain Type	Force N (lbs.)
UCF1G-01	Internal drain type	100 (22.5)
	External drain type	80 (18.0)
UCF1G-03	Internal drain type	170 (38.2)
	External drain type	90 (20.2)
UCF2G-03	Internal drain type	170 (38.2)
	External drain type	130 (29.2)
UCF1G-04	External drain type	170 (38.2)
UCF2G-04	External drain type	170 (38.2)

Note: The push down forces are with the maximum allowable pressure at the port concerned, which is controlled flow outlet "B" for internal drain types or the drain port for internal drain types.

#### Line filter

To carry out flow adjustments by as small degree as 2 L/min (.53 U. S. GPM) or less, be sure to use a line filter, 10 µm or less, near the valve inlet.

#### Flow adjustment

[UCF1G-01, UCF\*G-03]

Loosen the locking screw and turn the flow adjustment dial clockwise for increase, and anti-clockwise for decrease.

The dial makes about four revolutions from zero to full flow and the valve opening is indicated on the revolution indicator.

After flow adjustment, tighten the locking screw.

[UCF\*G-04]

Loosen the locking screw and turn the flow adjustment handle clockwise to increase, and anti-clockwise to decrease.

Open condition is indicated in digital-scale in built-in revolution indicator.

After flow adjustment, tighten the locking screw.

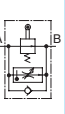

■ Min. Required Pressure Difference

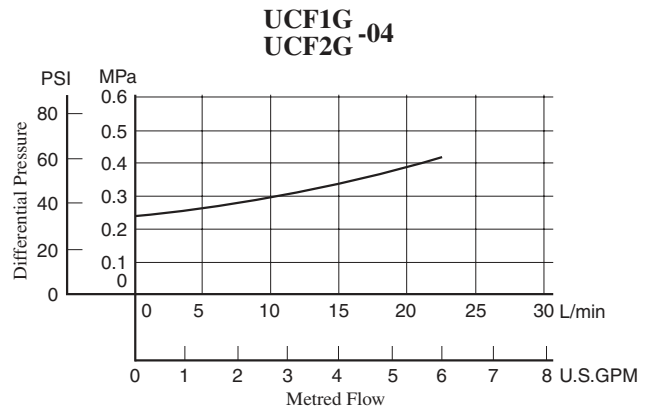
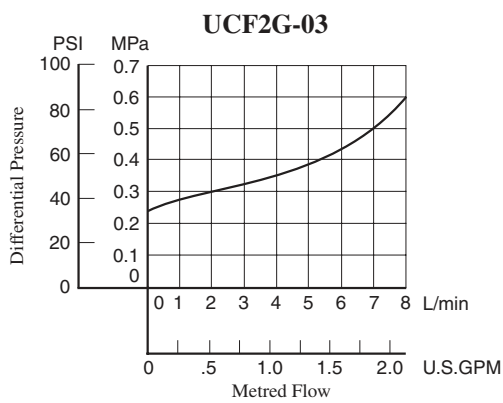
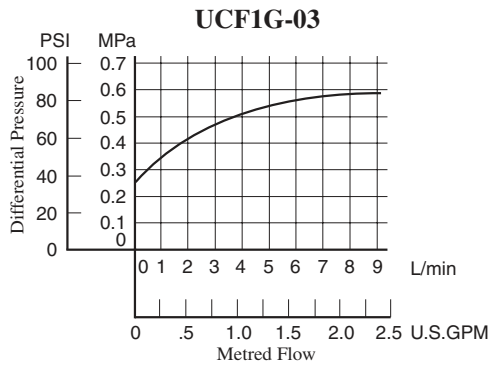
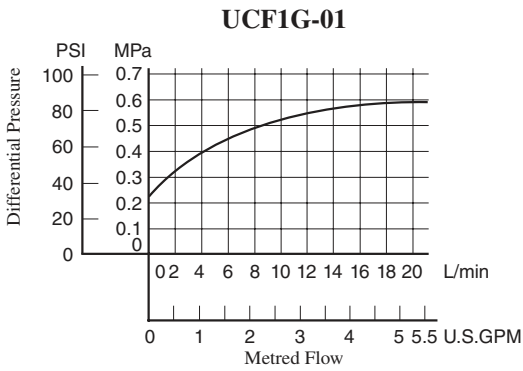

UCF1G-01-\*\*\*-11/1190

**DIMENSIONS IN MILLIMETRES (INCHES)**

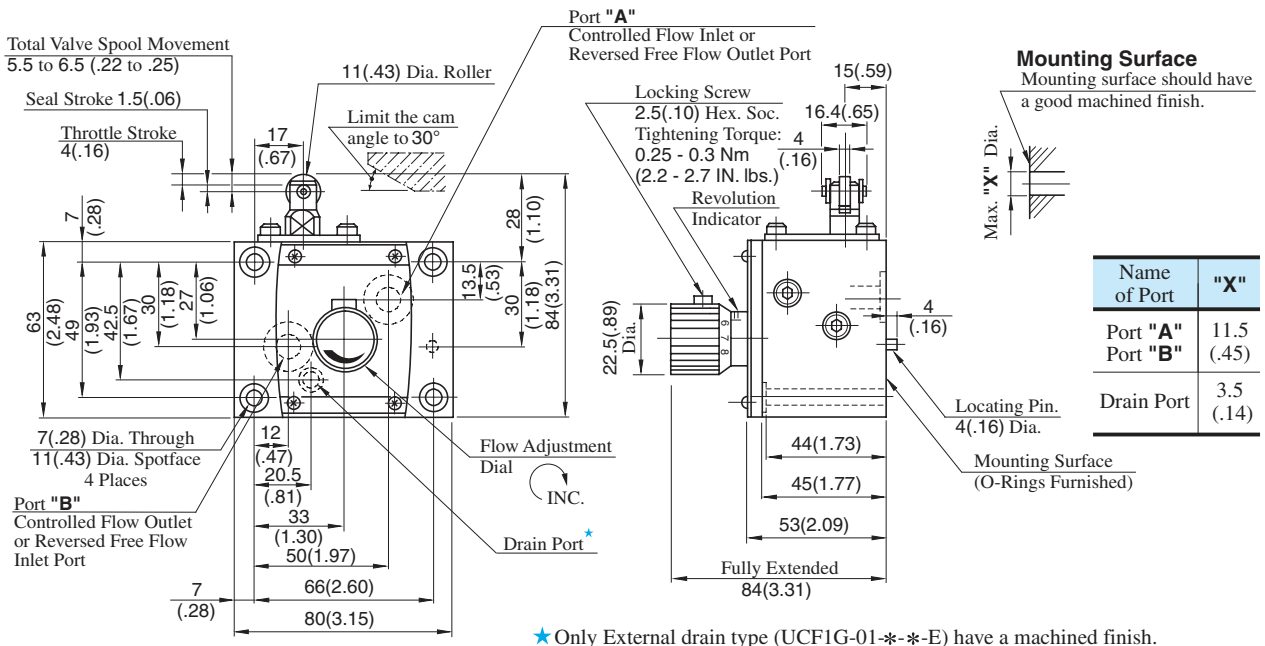



UCF1G-03-\*-10/1090

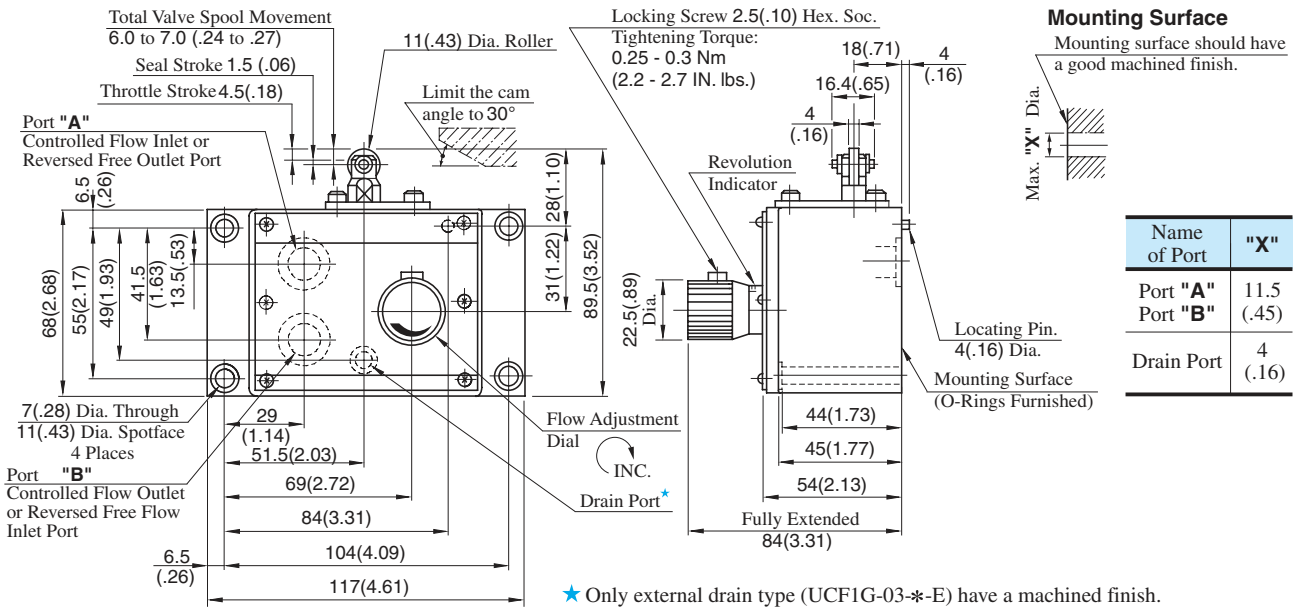

DIMENSIONS IN MILLIMETRES (INCHES)

UCF2G-03-\*-10/1090

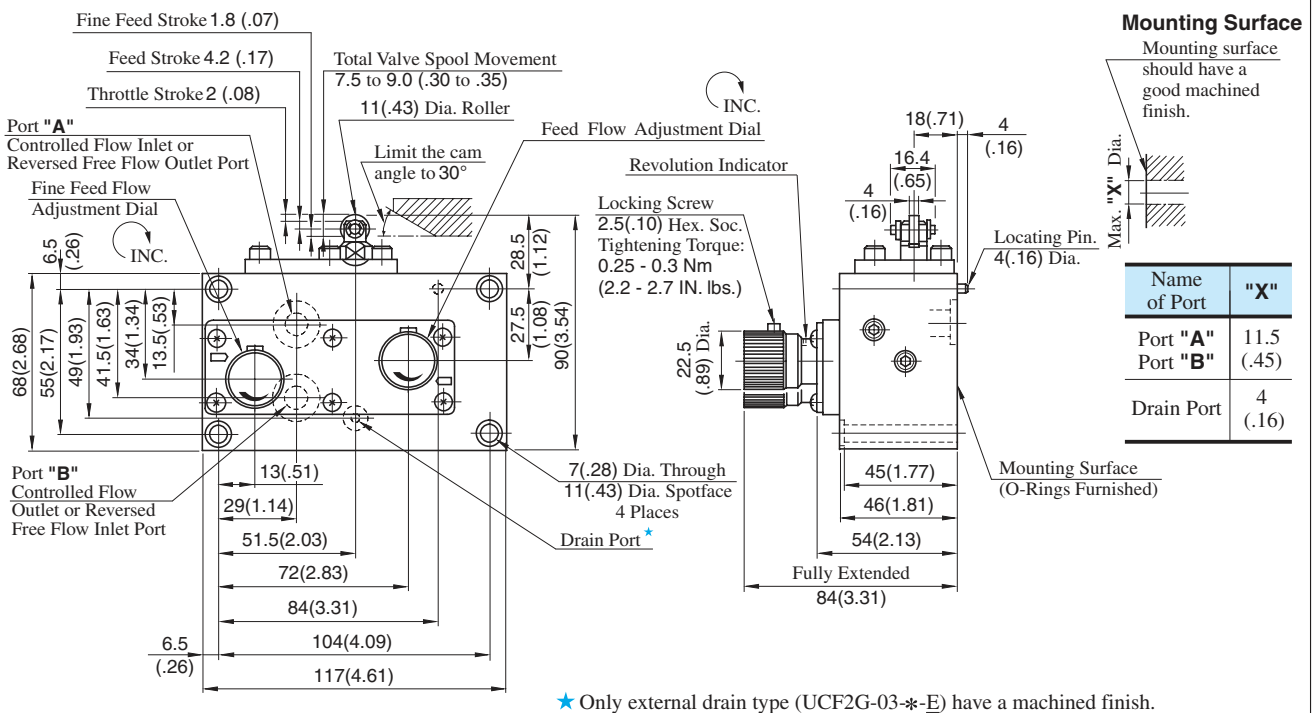

**UCF1G-04-30-30/3090**

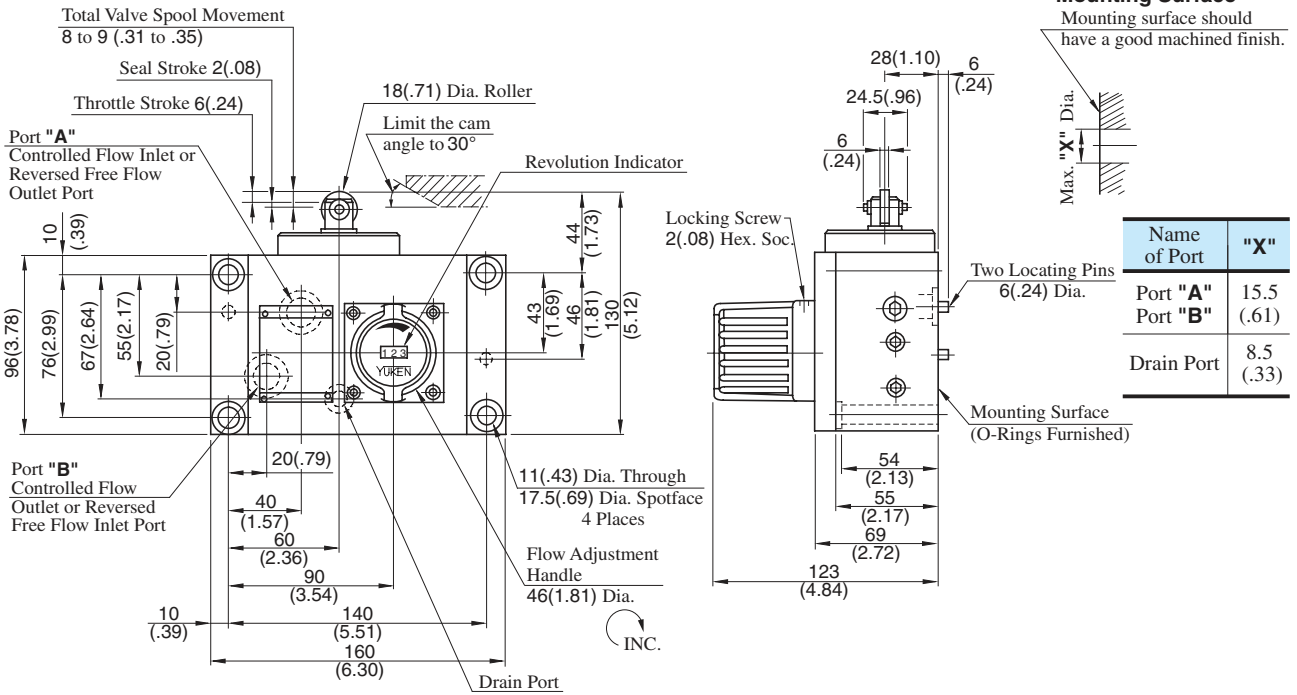

**DIMENSIONS IN MILLIMETRES (INCHES)**

**UCF2G-04-30-30/3090**

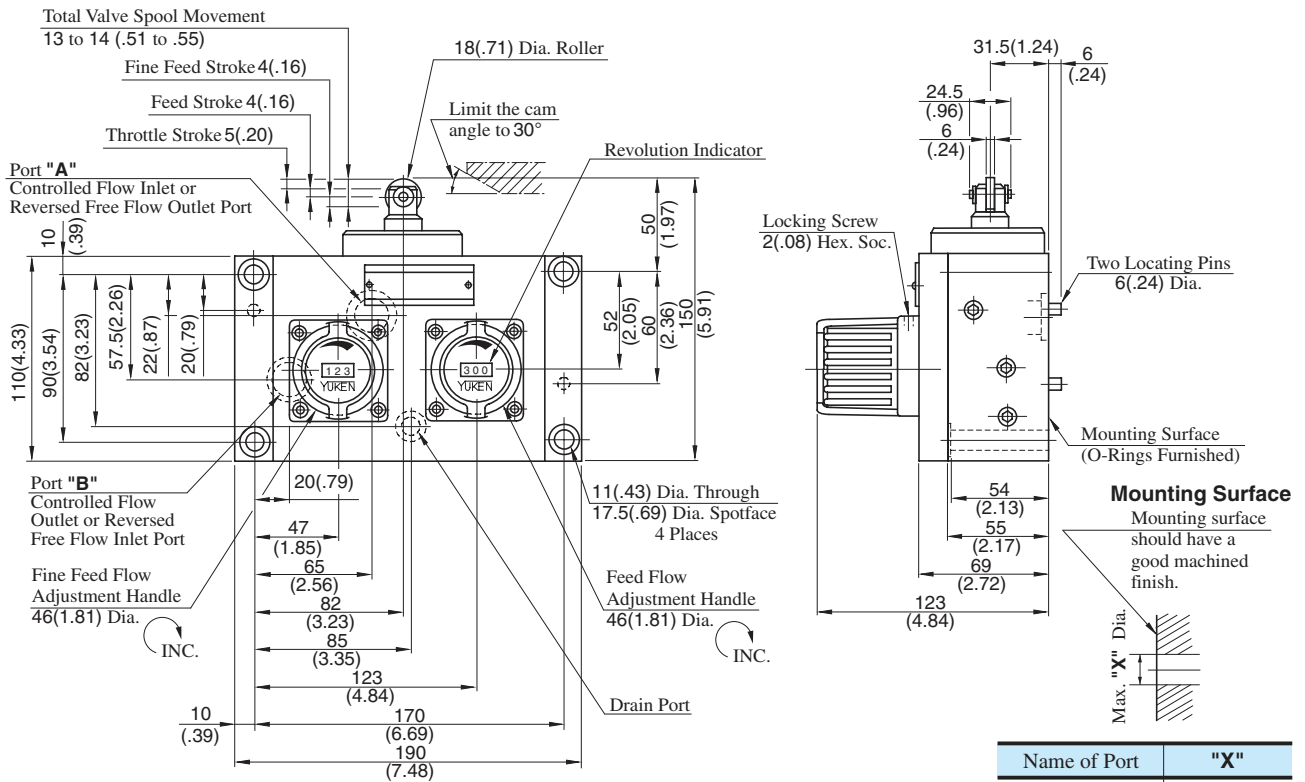



List of Seals

UCF1G-01-\*-\*\*-11/1190

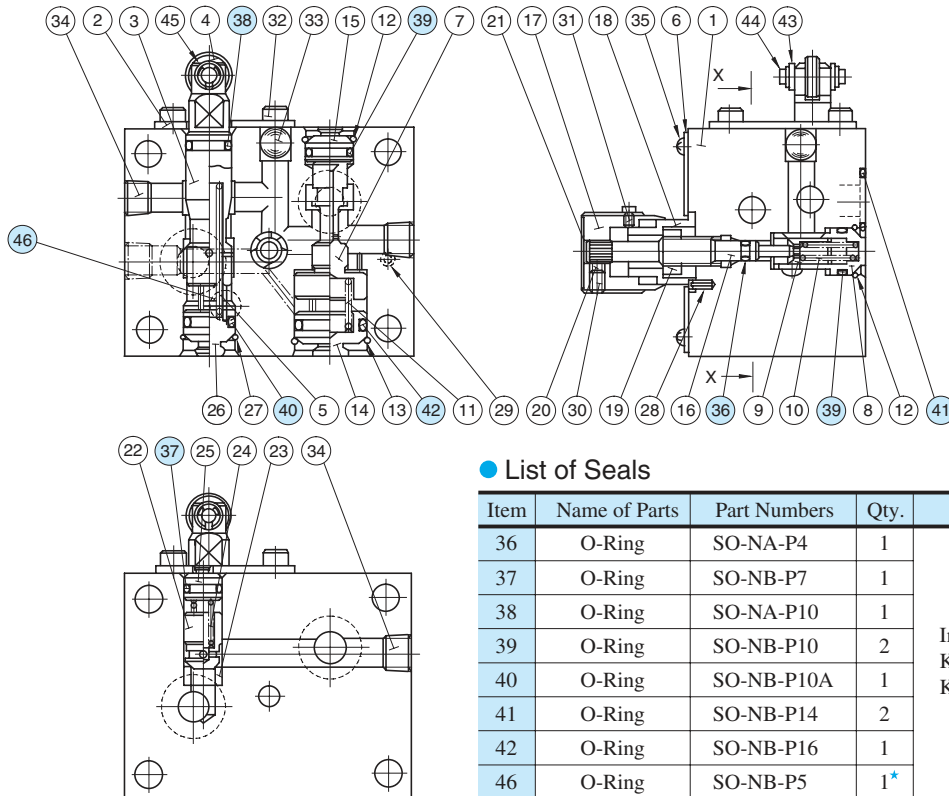

Section X-X

List of Seals

Item	Name of Parts	Part Numbers	Qty.	Remarks
36	O-Ring	SO-NA-P4	1	Included in Seal Kit Kit No: KS-UCF1G-01-11
37	O-Ring	SO-NB-P7	1	
38	O-Ring	SO-NA-P10	1	
39	O-Ring	SO-NB-P10	2	
40	O-Ring	SO-NB-P10A	1	
41	O-Ring	SO-NB-P14	2	
42	O-Ring	SO-NB-P16	1	
46	O-Ring	SO-NB-P5	1*	

★ Used only for external drain types (UCF1G-01-\*-\*\*-E-11\*).

UCF1G-03-\*-\*\*-10/1090

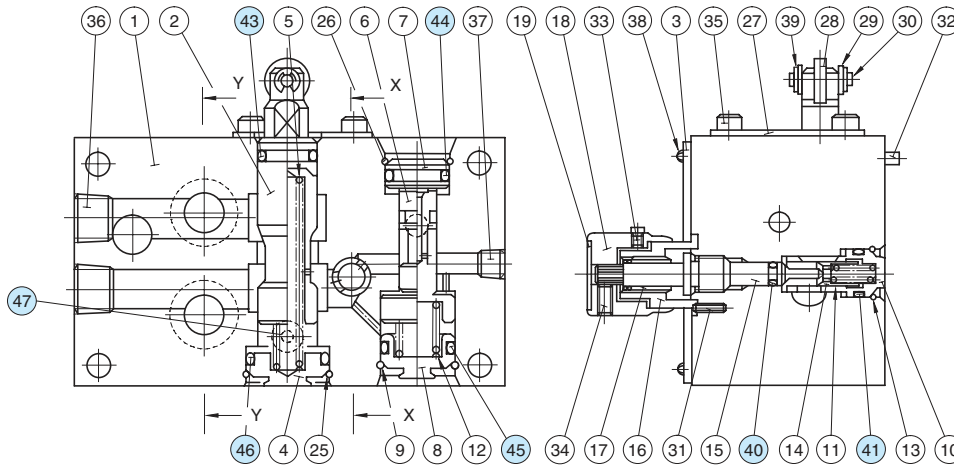

Section X-X

Section Y-Y

List of Seals

Item	Name of Parts	Part Numbers	Qty.	Remarks
40	O-Ring	SO-NA-P4	1	Included in Seal Kit Kit No: KS-UCF1G-03-10
41	O-Ring	SO-NB-P10	1	
42	O-Ring	SO-NB-P10A	1	
43	O-Ring	SO-NA-P12	1	
44	O-Ring	SO-NB-P14	3	
45	O-Ring	SO-NB-P16	1	
46	O-Ring	SO-NB-P18	1	
47	O-Ring	SO-NA-P6	1*	

★ Used only for external drain types (UCF1G-03-\*-\*\*-E-10\*).

**UCF2G-03-\*-10/1090**

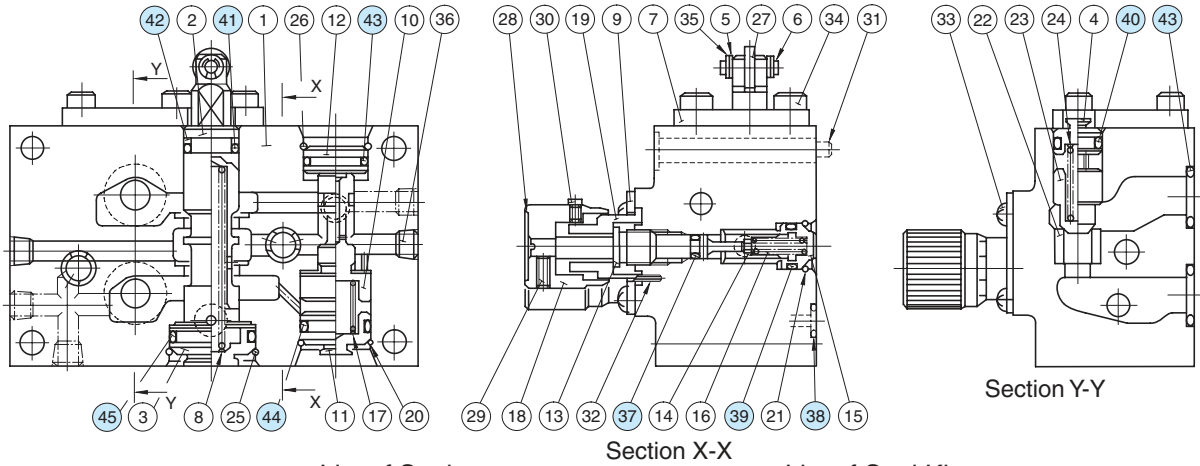

● List of Seals

Item	Name of Parts	Part Numbers	Qty.
37	O-Ring	SO-NA-P4	2
38	O-Ring	SO-NB-P6	1 <sup>*1</sup>
39	O-Ring	SO-NB-P10	2
40	O-Ring	SO-NB-P10A	1
41	O-Ring	SO-NA-P12	1
42	Back Up Ring	SO-BB-P12	1 <sup>*2</sup>
43	O-Ring	SO-NB-P14	3
44	O-Ring	SO-NB-P16	1
45	O-Ring	SO-NB-P21	1

● List of Seal Kits

Valve Model Numbers	Seal Kit Numbers
UCF2G-03-*-10*	KS-UCF2G-03-10
UCF2G-03-*-E-10*	KS-UCF2G-03-E-10

★ 1. Used only for external drain types (UCF2G-03-\*-E-10\*).

★ 2. Used only for internal drain types (UCF2G-03-\*-10\*).

Note: When ordering the seals, please specify the seal kit number from the table above.

**UCF1G-04-30-30/3090**  
**UCF2G-04-30-30/3090**

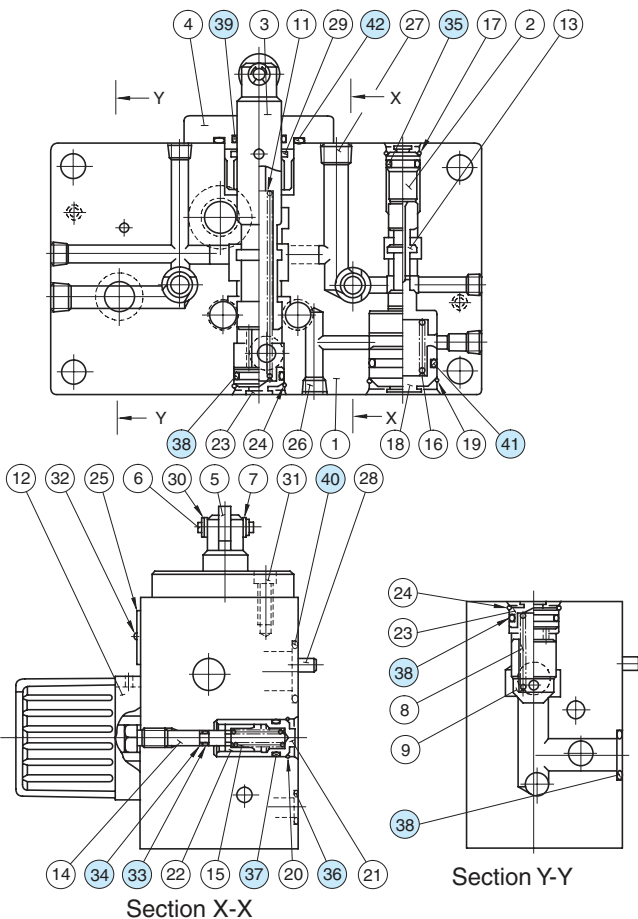

● List of Seals

Item	Name of Parts	Part Numbers	Quantity	
			UCF1G	UCF2G
33	O-Ring	SO-NA-P4	1	2
34	Back Up Ring	SO-BB-P4	1	2
35	O-Ring	SO-NB-P14	1	—
		SO-NB-P10A	—	1
36	O-Ring	SO-NB-P11	1	1
37	O-Ring	SO-NB-P12	1	2
38	O-Ring	SO-NB-P18	3	3
39	O-Ring	SO-NA-P20	1	1
40	O-Ring	SO-NB-P18	1	—
		SO-NB-P22A	—	1
41	O-Ring	SO-NB-G25	1	1
42	O-Ring	SO-NB-P34	1	1

Note: When ordering the seals, please specify the seal kit number from the table below.

● List of Seal Kits

Valve Model Numbers	Seal Kit Numbers
UCF1G-04	KS-UCF1G-04-30
UCF2G-04	KS-UCF2G-04-30

## Needle Valves

Used as stop valves for pressure gauge lines and small-capacity line. Also can be used as restrictors for regulating flow rates in pilot lines.

### Specifications

Model Numbers		Max. Flow L/min (U.S.GPM)	Max. Operating Pressure MPa (PSI)	Approx. Mass kg (lbs.)
In-Line Type	Angle Type			
GCT-02-32*	GCTR-02-32*	★	35 (5080 )	0.34 (.75)

★ Depends on allowable pressure drops. See Flow vs. Adjustment Revolutions characteristics and Pressure Drop at Full Open characteristics.



### Model Number Designation

F-	GCT	-02	-32	*
Special Seals	Series Number	Valve Size	Design Number	Design Standards
<b>F:</b> Special Seals for Phosphate Ester Type Fluids (Omit if not required)	<b>GCT :</b> In-line Type Needle Valve, Threaded Connection <b>GCTR :</b> Angle Type Needle Valve, Threaded Connection	<b>02</b>	<b>32</b>	Refer to ★

Graphic Symbol



★ Design Standards: None.....Japanese Standard "JIS"  
80.....European Design Standard  
90.....N. American Design Standard

### Flow vs. Adjustment Revolutions

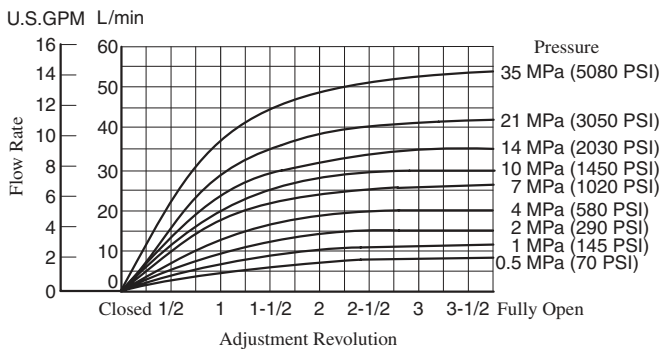

### Pressure Drop at Full Open

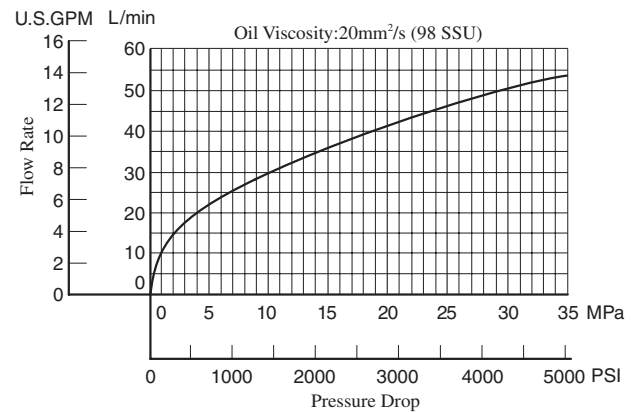

### Adaptor

Used where pressure gauges are attached directly to needle valves. Equipped with pressure snubber for reducing harmful surges to protect pressure gauges.

Adaptors are not accessories to needle valves. Order them referring to the table below. For the models shown here, only Japanese standard specifications are available.

AG-02S  
AG-03S  
AG-04S

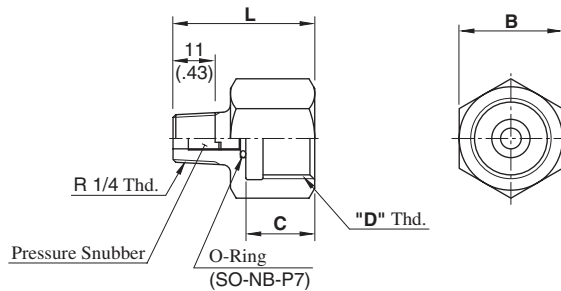

DIMENSIONS IN MILLIMETRES (INCHES)

Adaptor Type	Thread Size "D" Thd.	Dimensions mm (Inches)			Approx. Mass kg (lbs.)
		B	C	L	
AG-02S	G 1/4	24 (.94)	14 (.55)	32 (1.26)	0.075 (.165)
AG-03S	G 3/8	24 (.94)	16 (.63)	35 (1.38)	0.075 (.165)
AG-04S	G 1/2	27 (1.06)	18 (.71)	37 (1.46)	0.08 (.176)

**GCT-02-32/3280/3290**

M20 Thd.  
Lock Nut 24(.94) Hex.  
Fully Extended 82.5 (3.25)  
16 (.63)  
Outlet Port (Adaptor Mounting Side) "A" Thd.  
Inlet Port "A" Thd.  
50 (1.97)  
24 (.94)  
21 (.83) Dia.  
Max. 10 (.39)  
Panel mounting dimensions

Model Numbers	"A" Thd.	mm (Inches)	
		B	C
GCT-02-32	Rc 1/4	50 (1.97)	25 (.98)
GCT-02-3280	1/4 BSP.F	48 (1.89)	24 (.94)
GCT-02-3290	1/4 NPT	50 (1.97)	25 (.98)

**DIMENSIONS IN MILLIMETRES (INCHES)**

**GCTR-02-32/3280/3290**

M20 Thd.  
Lock Nut 24(.94) Hex.  
Fully Extended 82.5 (3.25)  
16 (.63)  
Outlet Port (Adaptor Mounting Side) "A" Thd.  
Inlet Port "A" Thd.  
50 (1.97)  
24 (.94)  
21 (.83) Dia.  
Max. 10 (.39)  
Panel mounting dimensions

Model Numbers	"A" Thd.	mm (Inches)
		B
GCTR-02-32	Rc 1/4	25 (.98)
GCTR-02-3280	1/4 BSP.F	24 (.94)
GCTR-02-3290	1/4 NPT	25 (.98)

**List of Seals**

GCT-02-32/3280/3290  
GCTR-02-32/3280/3290

**List of Seals**

Item	Name of Parts	Part Numbers	Qty.
5	O-Ring	SO-NA-P5	1
6	Back Up Ring	SO-BB-P5	1

Note : When ordering the seals, please specify the seal kit number from the table below.

**List of Seal Kits**

Valve Model Numbers	Seal Kit Numbers
GCT-02	KS-GCT-02-32
GCTR-02	

**Installation**

Refer to the following procedures to fit the valve with a panel. Figure in a circle below is shown on the above drawing.

1. Remove the nut ⑨ then take off the handle ⑧.
2. Take off the nut ③.
3. Insert the needle valve to a panel hole.
4. Screw the nut ③ onto the valve and fix the valve with the panel.
5. Fit the handle ⑧ and fix it with the nut ⑨.