

Product News

No. 10
03E
-1

YUKEN KOGYO CO.,LTD.
Public Relations Group
Products Publicity Section
Sales Administration Department
Hamamatsucho Seiwa Bdg., 4-8,
Shibadaimon 1-chome, Minato-ku,
Tokyo 105-0012, Japan
Tel: +81-3-3432-2113 Fax:+81-3-3436-2344



A7H Series High-Pressure Piston Pump

Release of New Products

Enhancing variety of variable piston pumps, 35MPa high pressure variable piston pump “A7H Series” is now on market.

■ Features

● High Pressure-Large Volume Displacement

Adding to current A3H series, 180 + 270 cm³/rev displacement with rated pres. 35MPa, Max. Pres. 40MPa pumps are now available.

● Optional Through Drive

Optional through drive allows an auxiliary or outboard pump (SAE Standard) to be directly mounted.

● Fire-Resistant Fluids

Water-Glycols and Polyol Ester Type are applicable under certain condition.



■ Specifications

Series Number	Geometric Displacement cm ³ /rev	Operating Pressure MPa		Shaft Speed Range r/min		Temperature Range °C	Viscosity Range mm ² /s	Approx. Mass kg	
		Rated	Intermittent (1)	Rated	Max. (2)			Flange Mtg.	Foot Mtg.
A7H180	180	35	40	1800	1900	-20-80	10-200 (200-1000) (3)	150 "01"	220 "01"
								154 "09"	224 "09"
A7H265	270	35	40	1200	1600			220 "01"	310 "01"
								224 "09"	314 "09"

(1) Ask Yuken for Max. Pres. operating condition.

(2) Max.Allowable Shaft Speed is specified when the suction pressure is -0.01 MPa ~.

(3) When the viscosity is more than 200mm²/s, system is required to be warmed up before operating at rated pressure.

■ Specifications for Special Fluids

Type of Fluids	Series Number	Operating Pressure MPa		Shaft Speed Range r/min		Temperature Range °C	Viscosity Range mm ² /s
		Rated	Intermittent (1)	Rated	Max. (2)		
Water-Glycols	M-A7H180	21	25	1800	1800	10-50	20-200 (200-1000)(3)
	M-A7H265	21	25	1200	1200		
Polyol Ester Type	P-A7H180	35	40	1800	1900	10-70	10-200 (200-1000)(3)
	P-A7H265	35	40	1200	1600		

(1) Ask Yuken for Max. Pres. operating condition.

(2) Max.Allowable Shaft Speed is specified when the suction pressure is -0.01 MPa ~.

(3) When the viscosity is more than 200mm²/s, system is required to be warmed up before operating at rated pressure.

■ Application

steel mill equipment, press machines and industrial machines

■ Product Release

We will start accepting orders for the products in October 2010.

Control Type and Graphic Symbols

Model Number	Control Type
A7H*-*R01S	Pressure Compensator Type
A7H*-*R09S	Constant Power Control Type
A7H*-*R09RS	Constant Power Control Type with External Pilot

Performance Characteristics

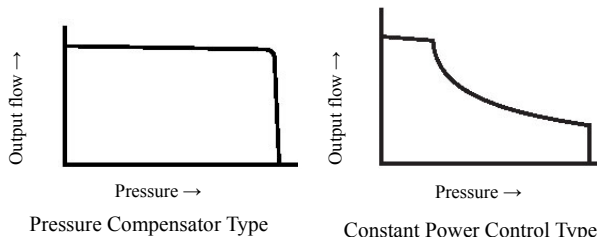

Pressure Compensator Type

Constant Power Control Type
Constant Power Control Type with External Pilot

Graphic Symbols

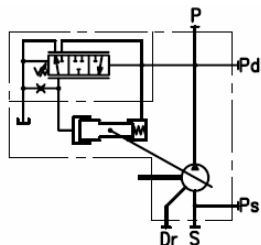

Pressure Compensator Type

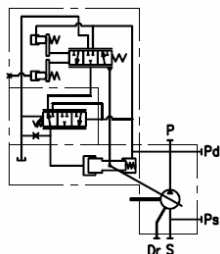

Constant Power Control Type

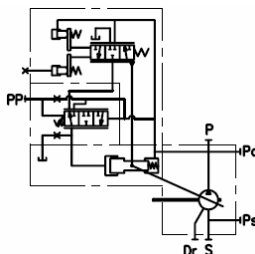

Constant Power Control Type with External Pilot

Model Number Designation

Pressure Compensator Type

M-	A7H265	-F	R	01	S	N	A	-10
Type of Fluids	Series Number	Mounting	Direction of Rotation	Control Type	Port Position	Pipe Flange	Outboard Pump Mounting Type	Design Number
None:Petroleum Base Oils (mineral oils) M:Water-Glycols P:Polyol Ester Type	A7H180 (180cm ³ /rev) A7H265 (270cm ³ /rev)	F: Flange Mtg. L: Foot Mtg.	R:Clockwise (Viewed from Shaft End)	01: Pressure Compensator Type (With Min. Flow Adj. Function)	S:Side Port	None: With Pipe Flange N: Without Pipe Flange	None:Without Mounting (With End Cover) A:SAE A B:SAE B C:SAE C CC:SAE CC D:SAE D	10

Constant Power Control Type and Constant Power Control Type with External Pilot

M-	A7H265	-F	R	09	R	S	N	A	M1	-10
Type of Fluids	Series Number	Mounting	Direction of Rotation	Control Type	External Pilot	Port Position	Pipe Flange	Outboard Pump Mounting Type	Code of Constant Power Control Type	Design Number
None:Petroleum Base Oils (mineral oils) M:Water-Glycols P:Polyol Ester Type	A7H180 (180cm ³ /rev) A7H265 (270cm ³ /rev)	F: Flange Mtg. L:Foot Mtg.	R: Clockwise (Viewed from Shaft End)	09: Constant Power Control Type	None: Without External Pilot R: With External Pilot	S:Side Port	None: With Pipe Flange N: Without Pipe Flange	None:Without Mounting (With End Cover) A:SAE A B:SAE B C:SAE C CC:SAE CC D:SAE D	Refer to below Code table	10

Code table of constant power control type

< A7H180 >					< A7H265 >			
Motor power kW	970 r/min	1150 r/min	1450 r/min	1750 r/min	Motor power kW	970 r/min	1150 r/min	1450 r/min
30	M4	-	-	-	45	M5	-	-
37	M2	M3	-	-	55	M3	M5	-
45	H5	M2	M4	-	75	H3	M1	M4
55	H3	H5	M2	M4	90	H2	H3	M2
75	-	H1	H4	M1	110	-	H1	H4
90	-	-	H2	H4	132	-	-	H2
110	-	-	-	H2				

■ Performance Characteristics of Constant Power Control Type

● A7H180

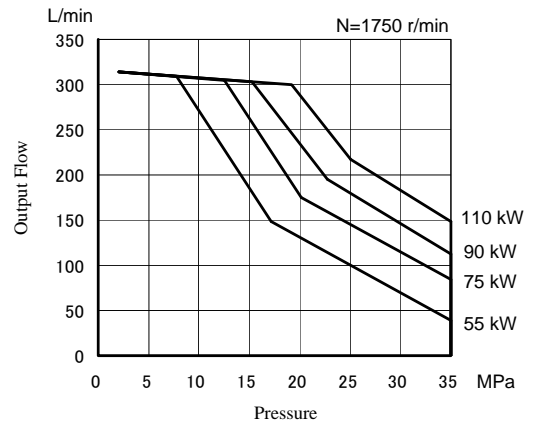
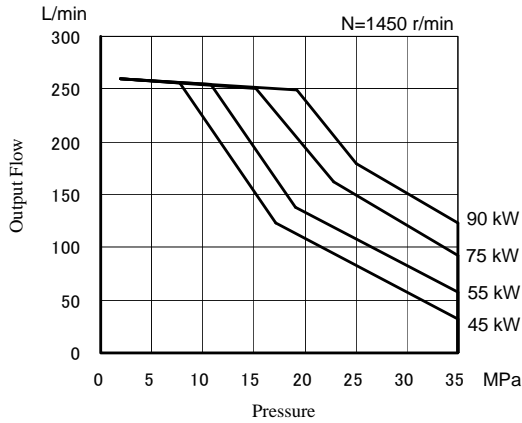
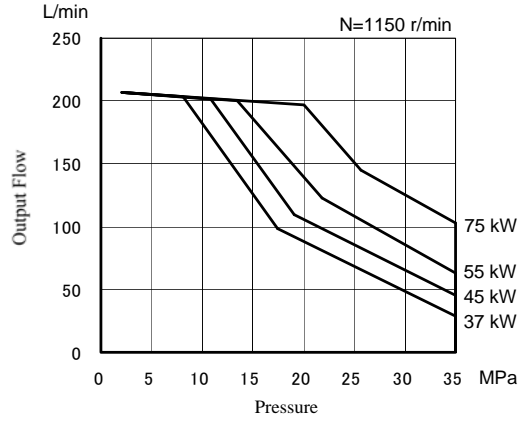
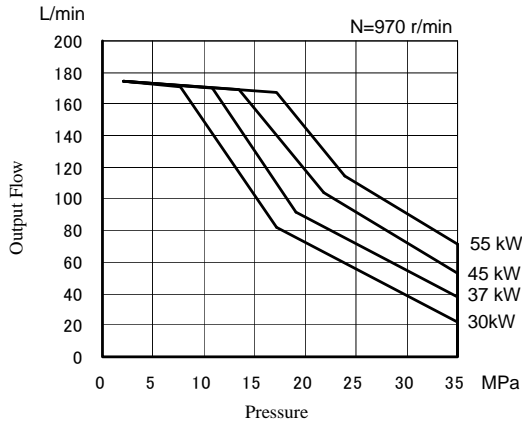

● A7H265

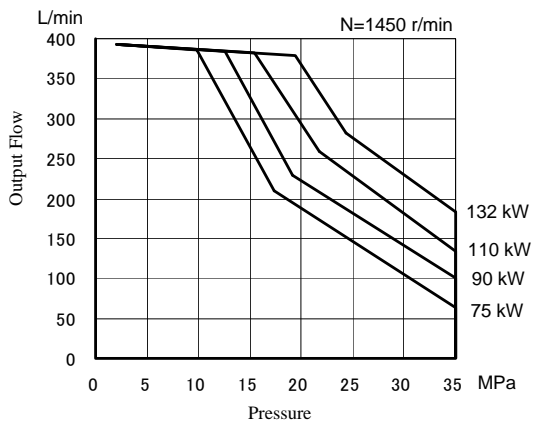
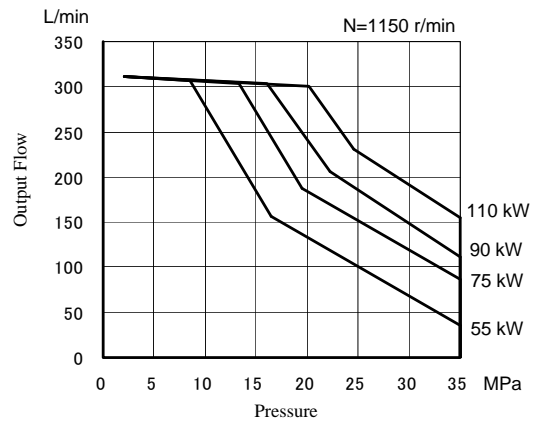
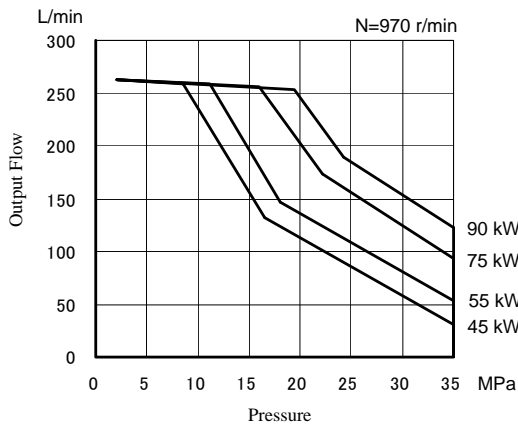

Typical Performance Characteristics of Type "A7H180" at Viscosity 20mm²/s [ISO VG 32 Oils, 50°C]

■ Performance Characteristic Curve

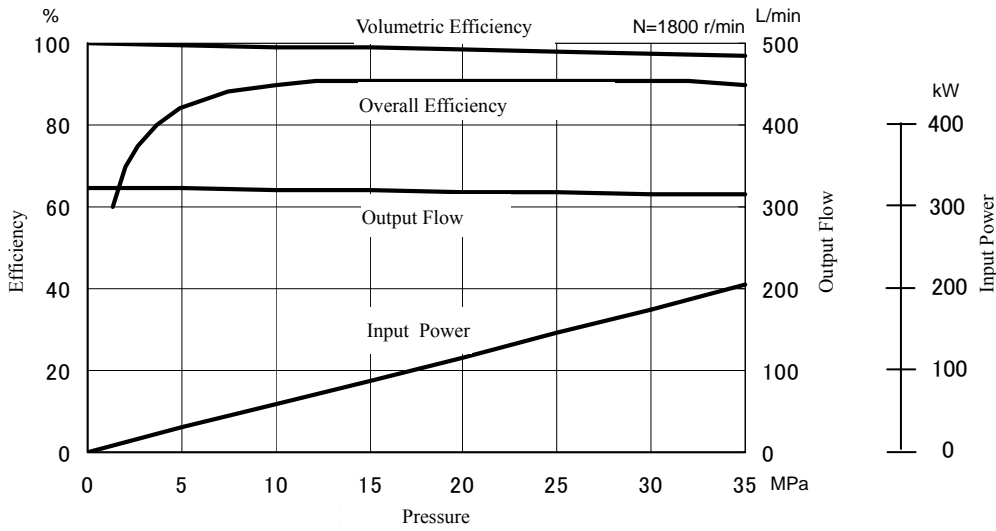

■ Full Cut-off Power

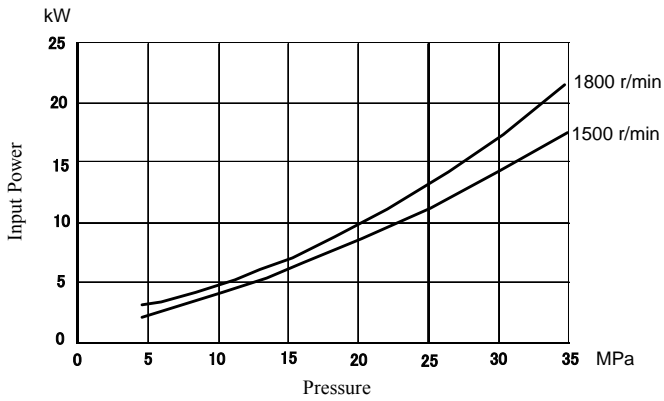

■ Drain

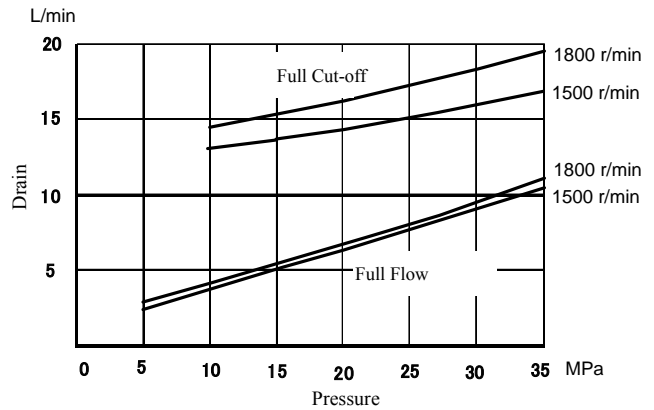

■ Suction

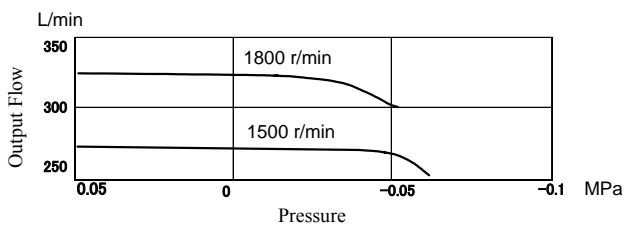

Typical Performance Characteristics of Type "A7H265" at Viscosity 20mm²/s [ISO VG 32 Oils, 50°C]

Performance Characteristic Curve

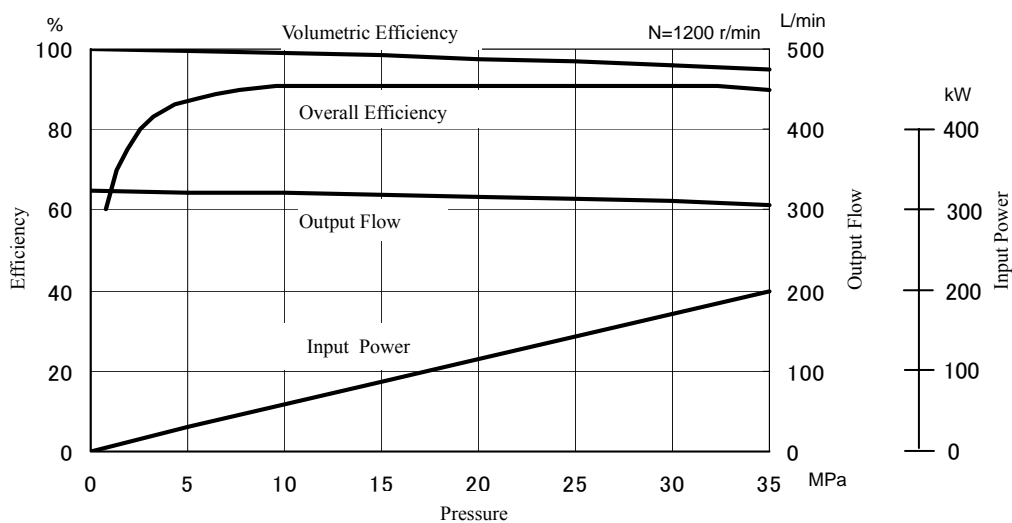

Full Cut-off Power

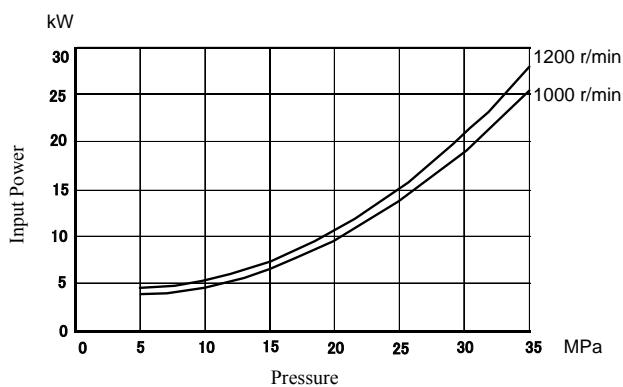

Drain

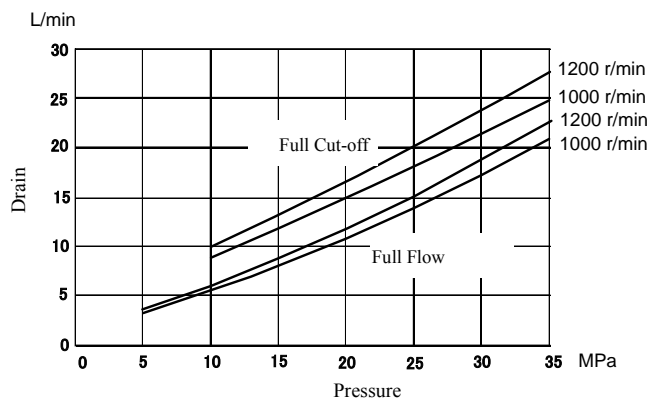

Suction

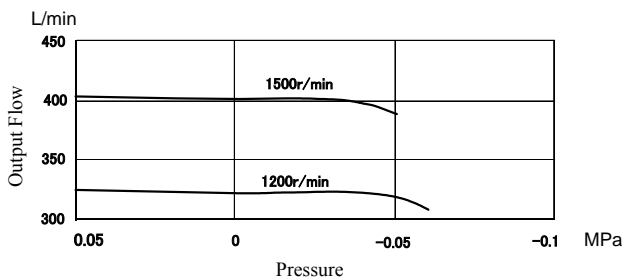

A7H180-**01

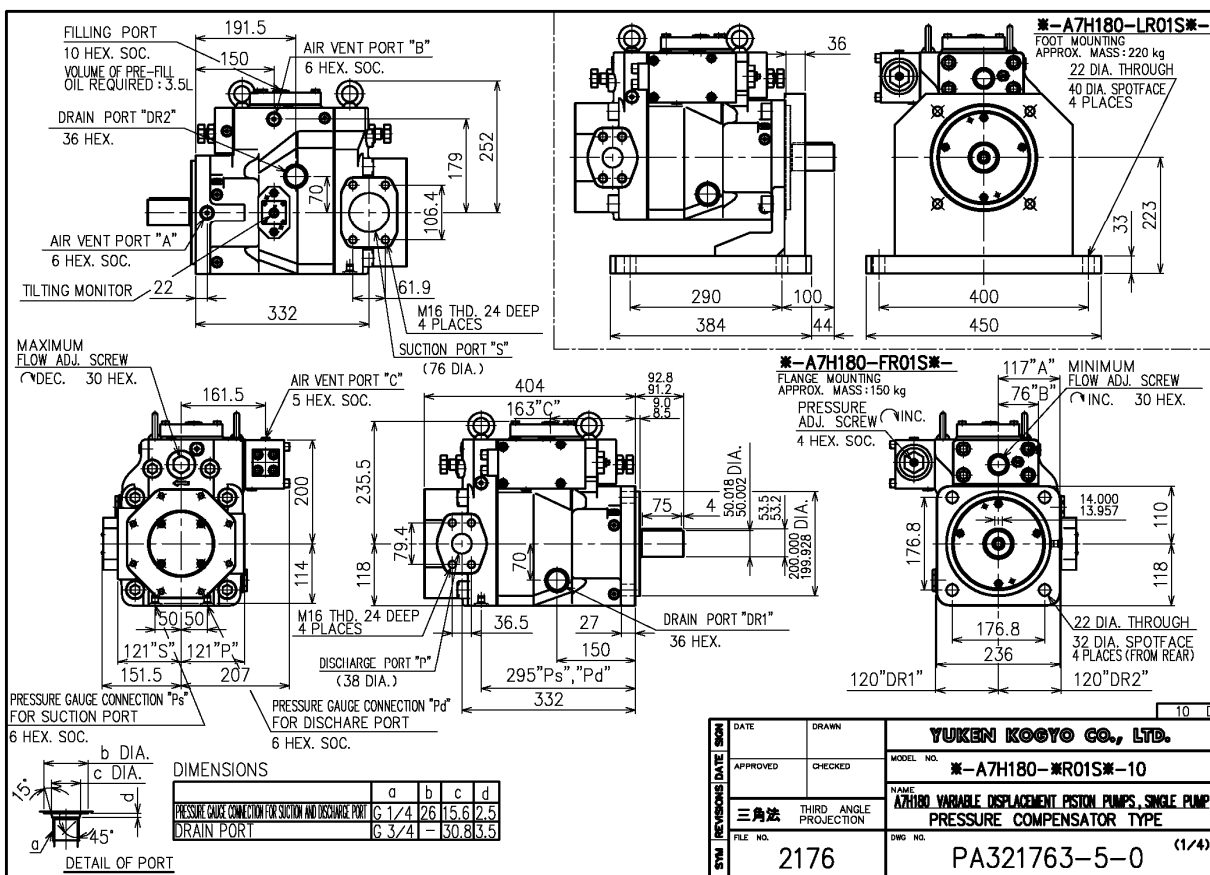

A7H180-**09

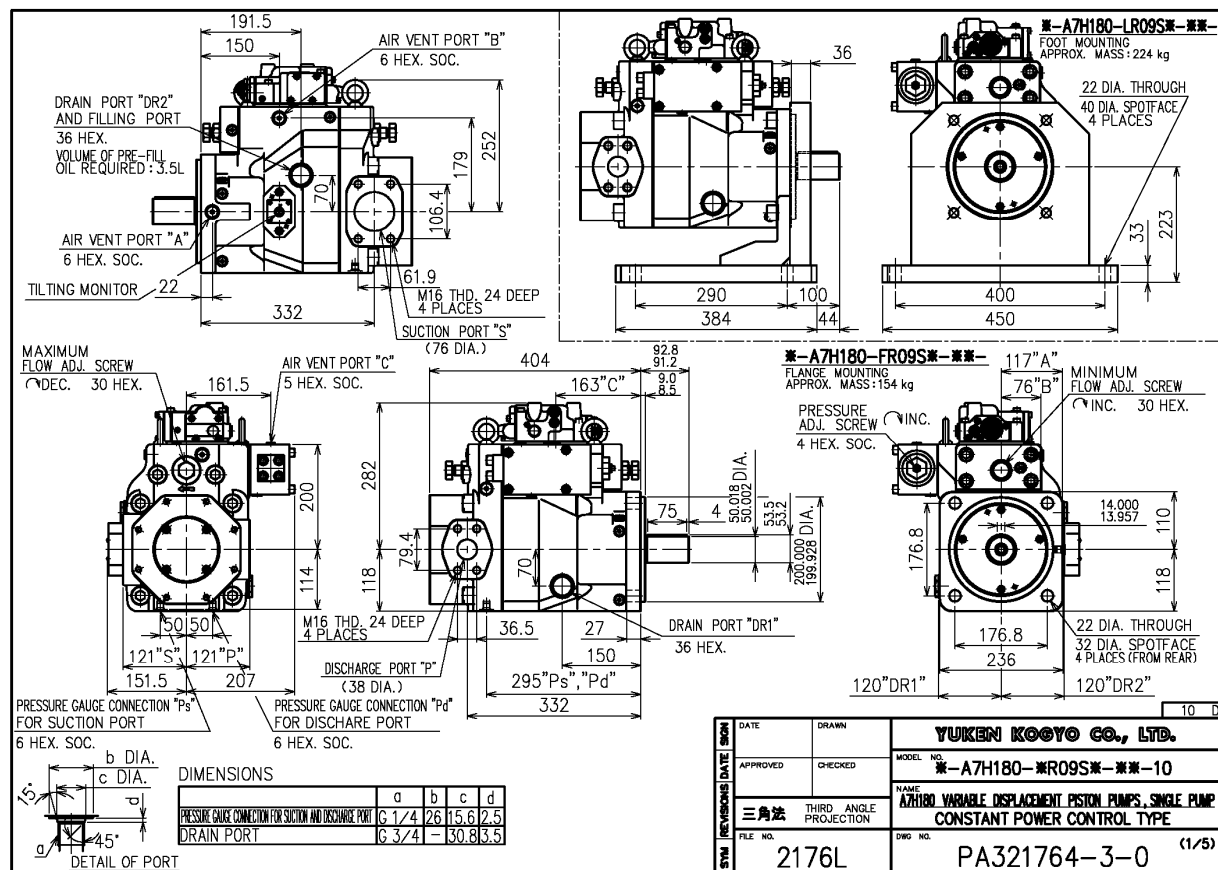

A7H180-**09R

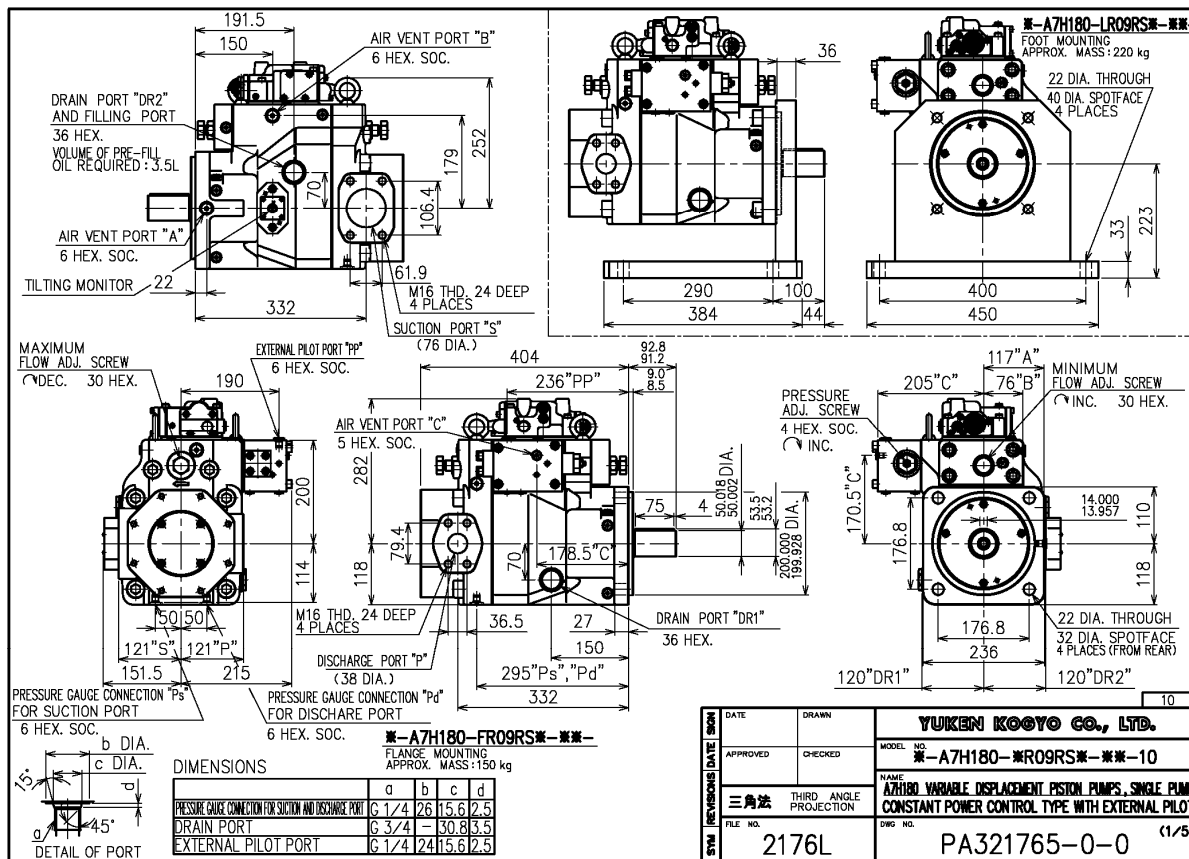

A7H265-**01

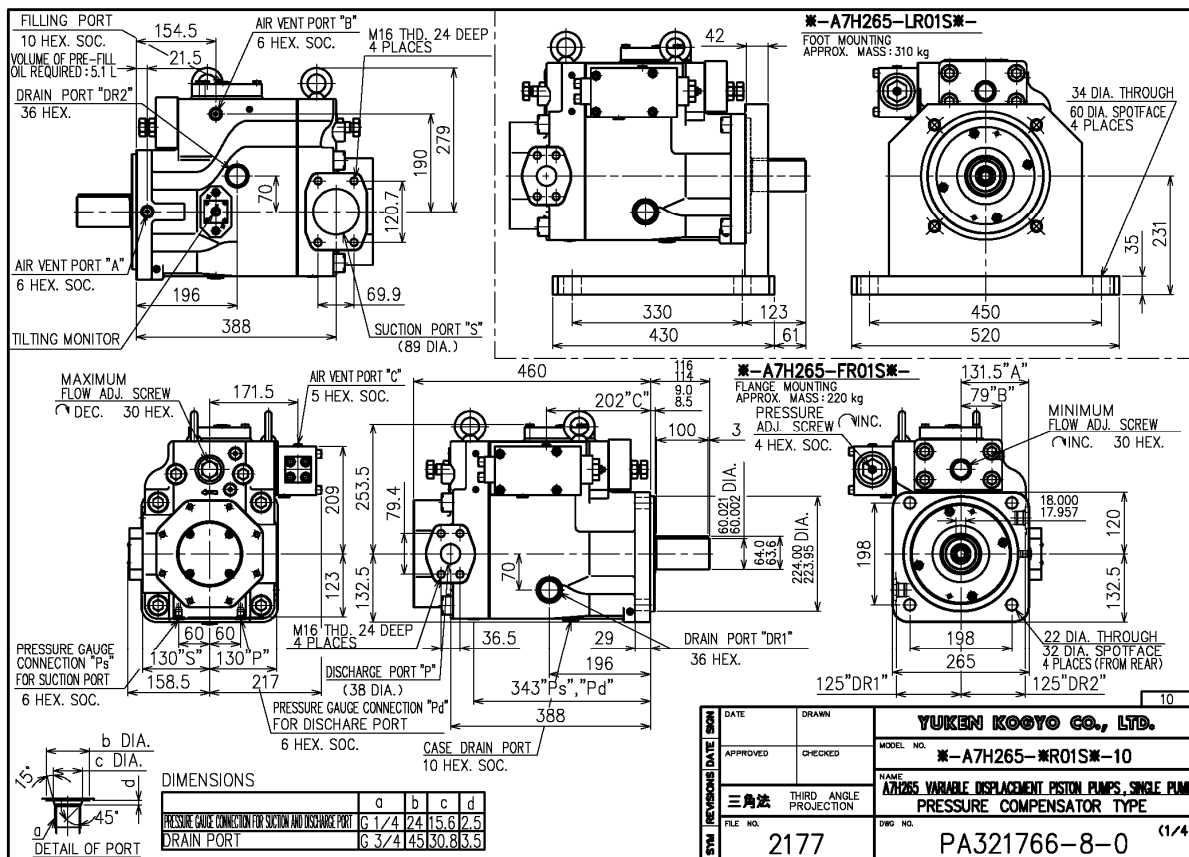

A7H265-**09

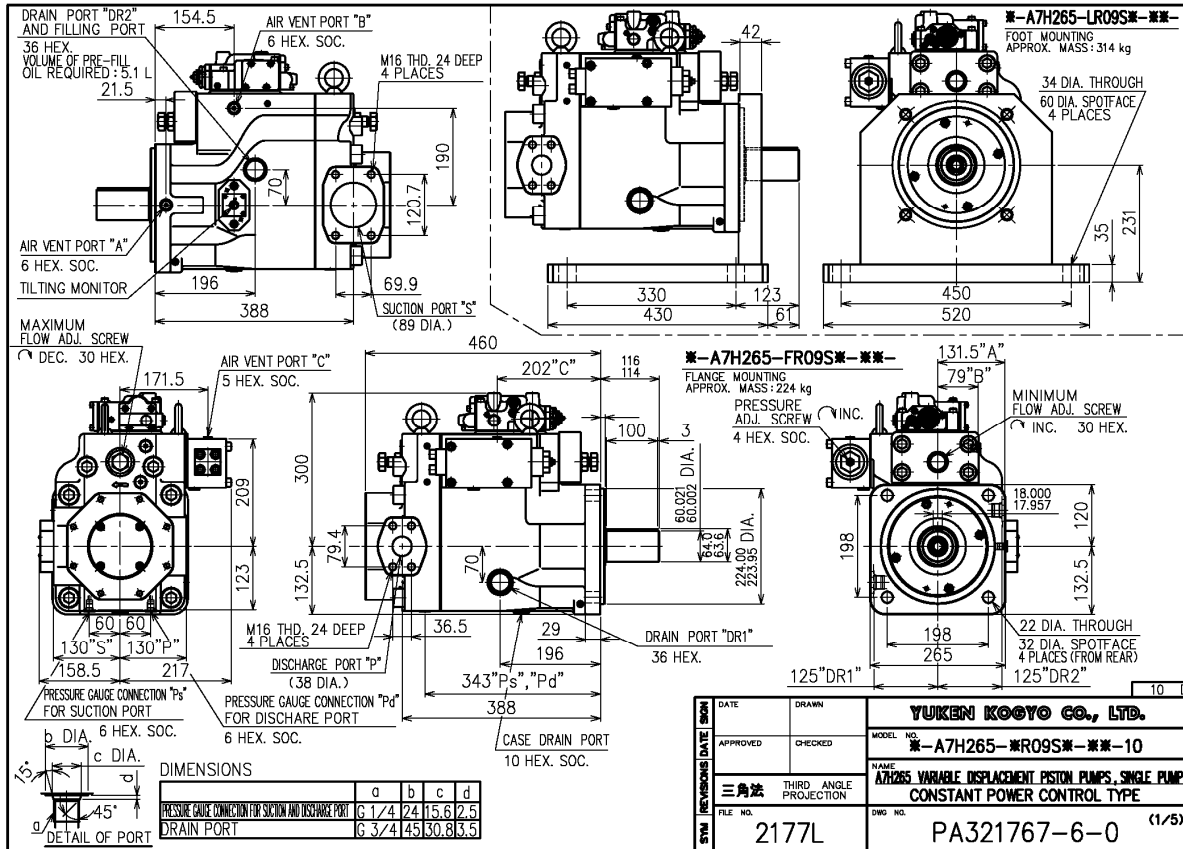

A7H265-**09R

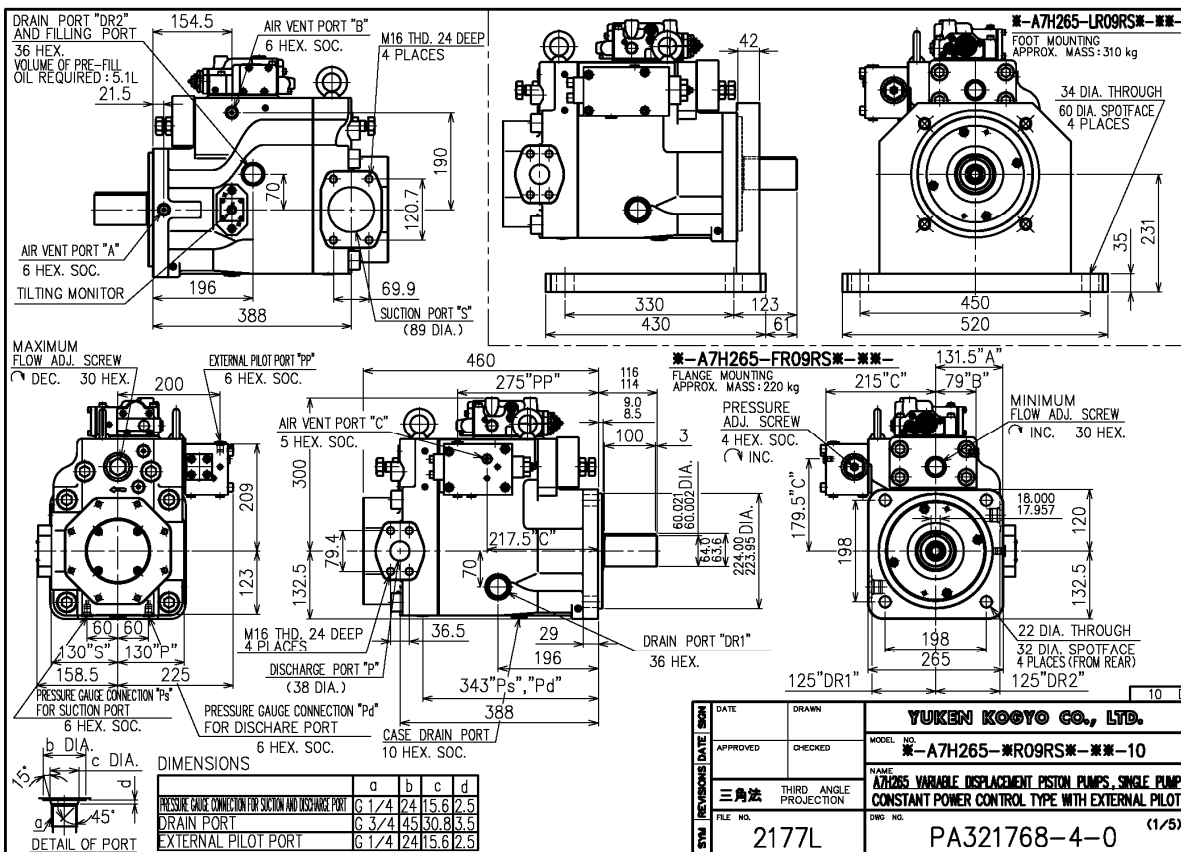

Outboard Pump Mounting Type "A7H180"

Pressure Compensator Type, Constant Power Control Type, Constant Power Control Type with External Pilot is common

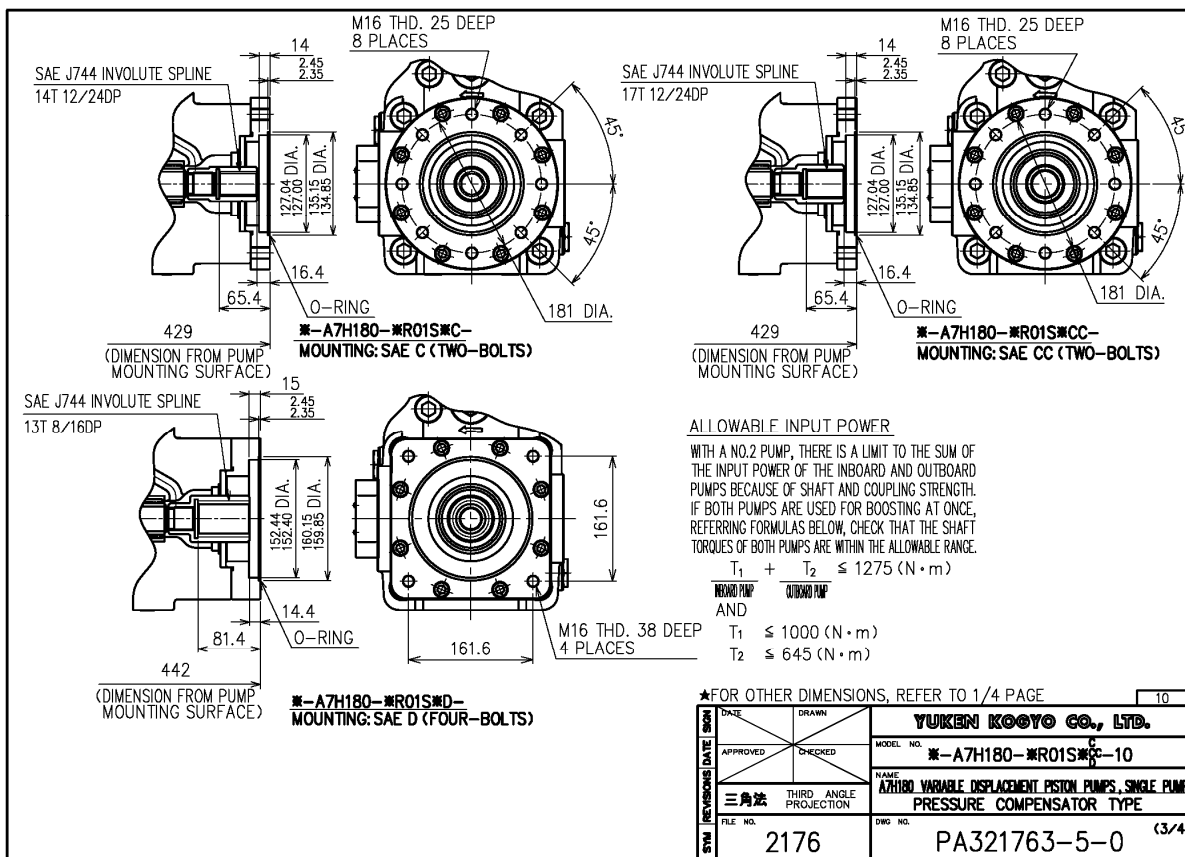
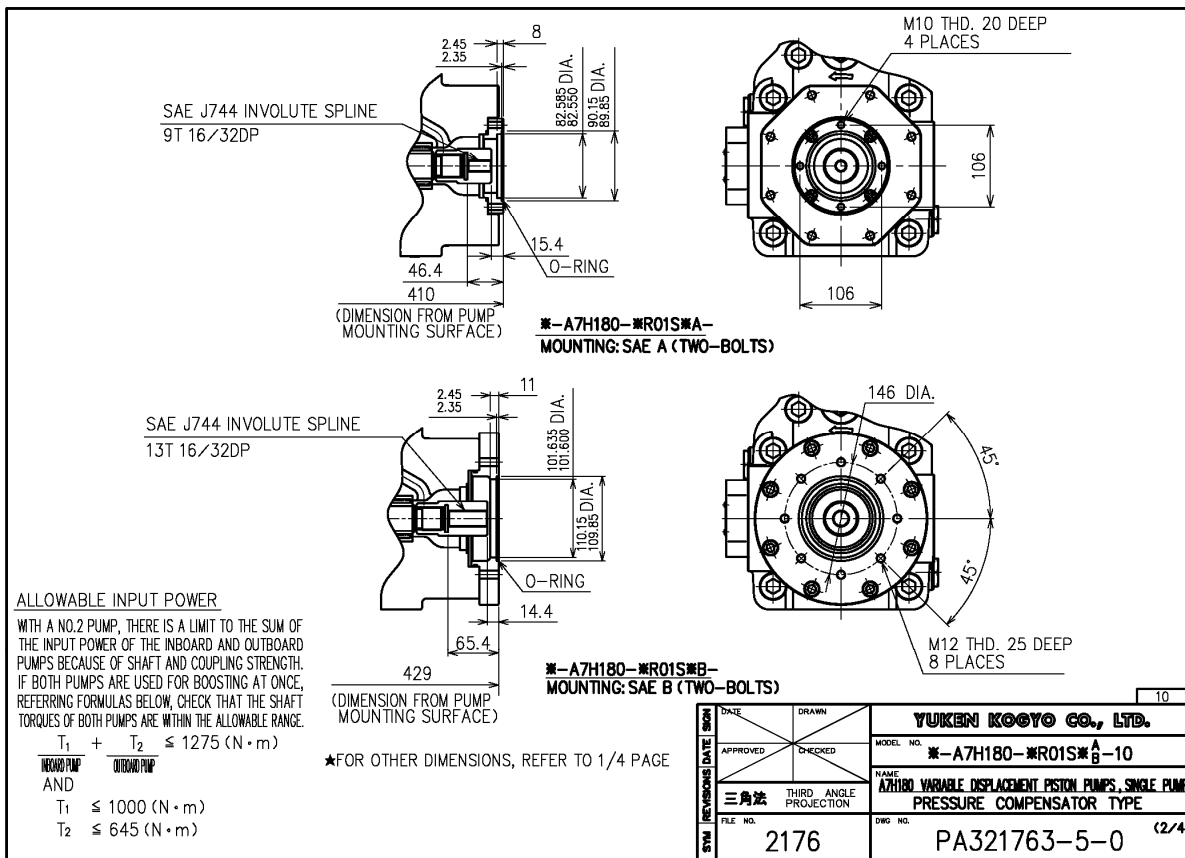

Outboard Pump Mounting Type "A7H265"

Pressure Compensator Type, Constant Power Control Type, Constant Power Control Type with External Pilot is common

SAE J744 INVOLUTE SPLINE
9T 16/32DP

(DIMENSION FROM PUMP MOUNTING SURFACE)

M10 THD. 20 DEEP
4 PLACES

106

106

■-A7H265-■R01S■A-
MOUNTING: SAE A (TWO-BOLTS)

SAE J744 INVOLUTE SPLINE
13T 16/32DP

(DIMENSION FROM PUMP MOUNTING SURFACE)

146 DIA.

45°

M12 THD. 25 DEEP
8 PLACES

■-A7H265-■R01S■B-
MOUNTING: SAE B (TWO-BOLTS)

ALLOWABLE INPUT POWER

WITH A NO.2 PUMP, THERE IS A LIMIT TO THE SUM OF THE INPUT POWER OF THE INBOARD AND OUTBOARD PUMPS BECAUSE OF SHAFT AND COUPLING STRENGTH. IF BOTH PUMPS ARE USED FOR BOOSTING AT ONCE, REFERRING FORMULAS BELOW, CHECK THAT THE SHAFT TORQUES OF BOTH PUMPS ARE WITHIN THE ALLOWABLE RANGE.

$$\frac{T_1}{\text{INBOARD PUMP}} + \frac{T_2}{\text{OUTBOARD PUMP}} \leq 2500 \text{ (N} \cdot \text{m)}$$

AND

$$T_1 \leq 1500 \text{ (N} \cdot \text{m)}$$

$$T_2 \leq 1000 \text{ (N} \cdot \text{m)}$$

★FOR OTHER DIMENSIONS, REFER TO 1/4 PAGE

DATE	DRAWN	YUKEN KOOYO CO., LTD.	
APPROVED	CHECKED	MODEL NO.	■-A7H265-■R01S■A-10
REVISIONS	DATE	NAME	A7H265 VARIABLE DISPLACEMENT PISTON PUMPS, SINGLE PUMP
三角法	THIRD ANGLE PROJECTION	TYPE	PRESSURE COMPENSATOR TYPE
FILE NO.	2177	DWG NO.	PA321766-8-0 (2/4)

SAE J744 INVOLUTE SPLINE
14T 12/24DP

(DIMENSION FROM PUMP MOUNTING SURFACE)

M16 THD. 25 DEEP
8 PLACES

181 DIA.

45°

■-A7H265-■R01S■C-
MOUNTING: SAE C (TWO-BOLTS)

SAE J744 INVOLUTE SPLINE
13T 8/16DP

(DIMENSION FROM PUMP MOUNTING SURFACE)

M16 THD. 38 DEEP
4 PLACES

161.6

45°

■-A7H265-■R01S■D-
MOUNTING: SAE D (FOUR-BOLTS)

ALLOWABLE INPUT POWER

WITH A NO.2 PUMP, THERE IS A LIMIT TO THE SUM OF THE INPUT POWER OF THE INBOARD AND OUTBOARD PUMPS BECAUSE OF SHAFT AND COUPLING STRENGTH. IF BOTH PUMPS ARE USED FOR BOOSTING AT ONCE, REFERRING FORMULAS BELOW, CHECK THAT THE SHAFT TORQUES OF BOTH PUMPS ARE WITHIN THE ALLOWABLE RANGE.

$$\frac{T_1}{\text{INBOARD PUMP}} + \frac{T_2}{\text{OUTBOARD PUMP}} \leq 2500 \text{ (N} \cdot \text{m)}$$

AND

$$T_1 \leq 1500 \text{ (N} \cdot \text{m)}$$

$$T_2 \leq 1000 \text{ (N} \cdot \text{m)}$$

★FOR OTHER DIMENSIONS, REFER TO 1/4 PAGE

DATE	DRAWN	YUKEN KOOYO CO., LTD.	
APPROVED	CHECKED	MODEL NO.	■-A7H265-■R01S■C-10
REVISIONS	DATE	NAME	A7H265 VARIABLE DISPLACEMENT PISTON PUMPS, SINGLE PUMP
三角法	THIRD ANGLE PROJECTION	TYPE	PRESSURE COMPENSATOR TYPE
FILE NO.	2177	DWG NO.	PA321766-8-0 (3/4)