

Pilot Operated Flow Control Valves / Pilot Operated Flow Control and Check Valves

Flow control of these valves is continuously made by a hydraulically operated pilot piston mechanism which controls opening area of the orifice of the valve. With the use of these valves, shockless operation either in acceleration or deceleration can be obtained. With the compensator for the pressure and temperature, stable flow control can be obtained regardless of the changes in the pressure (load) and temperature (oil viscosity).

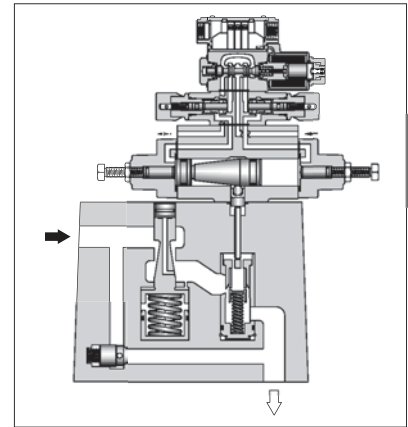

Graphic Symbols

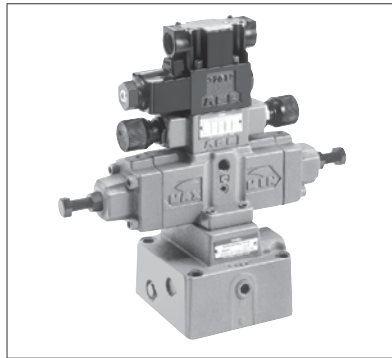
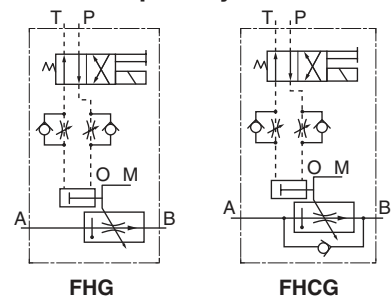

Specifications

Model Numbers	Max. Metred Flow Capacity L/min (U.S.GPM)	Min. Metred Flow Capacity L/min (U.S.GPM)	Max. Operating Pressure MPa (PSI)	Min. Pilot Pressure MPa (PSI)	Approx. Mass kg (lbs.)
FHG/FHCG-02-30-*-13*	30 (7.9)	0.05 (.013)	21 (3050)	1.5 (220)	13 (28.7)
FHG/FHCG-03-125-*-13*	125 (33)	0.2 (.053)			17 (37.5)
FHG/FHCG-06-250-*-13*	250 (66)	2 (.53)			32 (70.6)
FHG/FHCG-10-500-*-13*	500 (132)	4 (1.06)			61 (135)

Model Number Designation

F-	FHC	G	-02	-30	-N	-O	-A100	-N	-13	*
Special Seals	Series Number	Type of Mounting	Valve Size	Max. Metred Flow L/min (U.S.GPM)	Pressure <sup>*3</sup> Compensator Stroke Adj.	With No Pilot Valve <sup>*1</sup>	Coil <sup>*2</sup> Type	Type of Electrical Connections	Design Number	Design Standards
<b>F:</b> Special Seals for Phosphate Ester Type Fluids (Omit if not required)	<b>FH:</b> Pilot Operated Flow Control Valves <b>FHC:</b> Pilot Operated Flow Cont. & Check Valves	<b>G:</b> Sub-plate Mounting	<b>02</b>	<b>30:</b> 30 (7.9)	<b>N:</b> Applicable only for Pres. Compensator Stroke Adjustment (Option - Omit if not required)	<b>O:</b> Applicable only for Without Pilot Valve	<b>AC:</b> <b>A100</b> <b>A120</b> <b>A200</b> <b>A240</b> <b>DC:</b> <b>D12</b> <b>D24</b> <b>D48</b> <b>AC → DC:</b> <b>R100</b> <b>R200</b>	<b>None:</b> Terminal Box Type <b>N:</b> With Plug-in Connector (Din) <b>N:</b> With Plug-in Connector (Din)	<b>13</b>	<b>None:</b> Japanese Std. "JIS" <b>90:</b> N.American Design Std. <b>80:</b> European Design Std.
			<b>03</b>	<b>125:</b> 125 (33)					<b>13</b>	
			<b>06</b>	<b>250:</b> 250 (66)					<b>13</b>	
			<b>10</b>	<b>500:</b> 500 (132)					<b>13</b>	

- \*1. Both solenoid operated directional valve (DSG-01) and modular valve (MSW-01) can be used as a pilot valve. If no pilot valve is required, there is no need to specify the coil type and the electrical connection type of solenoid operated directional valve.
- \*2. The coil types are same as those for DSG-01 Series solenoid operated directional valves. See solenoid ratings on page 345.
- \*3. **Pres. compensator stroke adjustment:** Can reduce jumping at the start of the actuator.

In the table above, the symbols or numbers highlighted with shade represent the optional extras. The valves with model number having such optional extras are handles as options, therefore, please confirm the time of delivery with us before ordering.

Attachment  
Mounting Bolts

Valve Model Numbers	Socket Head Cap Screw		Qty.
	Japanese Std. "JIS" & European Design Std.	N. American Design Std.	
FHG/FHCG-02	M8×50 Lg.	5/16-18 UNC ×2 Lg.	4
FHG/FHCG-03	M10×75 Lg.	3/8-16 UNC ×3 Lg.	4
FHG/FHCG-06	M16×130 Lg.	5/8-11 UNC ×5 Lg.	4
FHG/FHCG-10	M20×160 Lg.	3/4-10 UNC ×6-1/2 Lg.	4

D Pilot Operated Flow Control Valves Pilot Operated Flow Control and Check Valves

**Sub-plate**

Valve Model Numbers	Japanese Standard "JIS"		European Design Std.		N. American Design Std.		Approx. Mass kg (lbs.)
	Sub-plate Model No.	Thread Size	Sub-plate Model No.	Thread Size	Sub-plate Model No.	Thread Size	
FHG FHCG -02	FGM-02-20	Rc 1/4	FGM-02-2080	1/4 BSP.F	FGM-02-2090	1/4 NPT	2.3 (5.1)
	FGM-02X-20	Rc 3/8	FGM-02X-2080	3/8 BSP.F	FGM-02X-2090	3/8 NPT	2.3 (5.1)
	FGM-02Y-20	Rc 1/2	FGM-02Y-2080	1/2 BSP.F	FGM-02Y-2090	1/2 NPT	3.1 (6.8)
FHG FHCG -03	FGM-03-20	Rc 3/8	FGM-03-2080	3/8 BSP.F	FGM-03-2090	3/8 NPT	3.9 (8.6)
	FGM-03X-20	Rc 1/2	FGM-03X-2080	1/2 BSP.F	FGM-03X-2090	1/2 NPT	3.9 (8.6)
	FGM-03Y-20	Rc 3/4	FGM-03Y-2080	3/4 BSP.F	FGM-03Y-2090	3/4 NPT	5.7 (12.6)
	FGM-03Z-20	Rc 1	FGM-03Z-2080	1 BSP.F	FGM-03Z-2090	1 NPT	5.7 (12.6)
FHG FHCG -06	FGM-06X-20	Rc 1	FGM-06X-2080	1 BSP.F	FGM-06X-2090	1 NPT	12.5 (27.6)
	FGM-06Y-20	Rc 1-1/4	FGM-06Y-2080	1-1/4 BSP.F	FGM-06Y-2090	1-1/4 NPT	16 (35.3)
	FGM-06Z-20	Rc 1-1/2	FGM-06Z-2080	1-1/2 BSP.F	FGM-06Z-2090	1-1/2 NPT	16 (35.3)
FHG FHCG -10	FGM-10Y-20★	1-1/2, 2	FGM-10Y-20★	1-1/2, 2	FGM-10Y-2090★	1-1/2, 2	37 (81.6)

- Sub-plates are available. Specify the sub-plate model number from the table above. When sub-plates are not used, the mounting surface should have a good machined finish.
- ★ FGM-10Y is special type sub-plates to be used with pipe flange. When ordering FGM-10Y, specify the pipe flange kit in addition to FGM-10Y referring to F3 pipe flanges shown on page 821.

- Sub-plates are common with flow control valves. For dimensions, see pages 281 to 283.

**Instructions**

**Control patterns and flow rate adjustment**

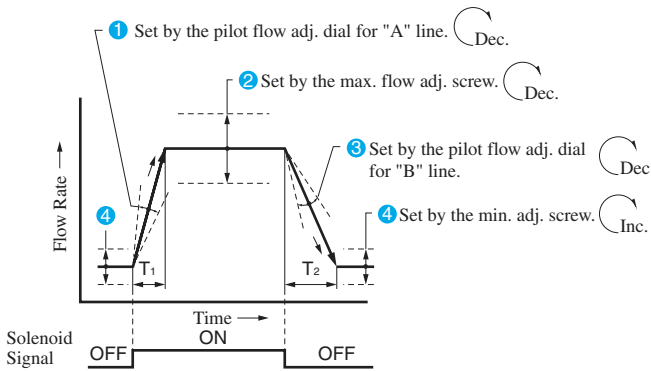

- While the solenoid operated directional valve off (4 shown left)  
The flow rate is set by the minimum flow adjustment screw and the actuator operates at the minimum speed setting.
- When the solenoid operated directional valve is turned on (1 shown left)  
The flow rate is shifted from minimum to maximum and the actuator speed is also shifted likewise. The switching time can be set by the pilot flow adjustment dial 1.
- When the solenoid operated directional valve is turned off (3 shown left)  
The flow rate is shifted from maximum to minimum and the actuator speed is also shifted likewise. The switching time can be set by the pilot flow adjustment dial 3.

**Tightening of flow adjustment screws and dials**

To adjust flow rates, slacken the lock nut or the dial setting screw. After adjustments, tighten the lock nut or the dial.

**Min. required pressure difference**

The minimum differential pressure between inlet and outlet port is required to obtain the optimum pressure compensation. It varies according to the flow rate to be set. For details, please refer to the performance curves.

**Free flow**

Check valve pressure drops vary with flow rates. If models with check valves are used, see free flow pressure drop characteristics.

**Line filter**

To carry out flow adjustments by as small degree as 2 L/min (.53 U.S.GPM) or less, be sure to use a line filter of 10 μm or finer and install it near the valve inlet.

## Metred Flow vs. Cylinders Stroke

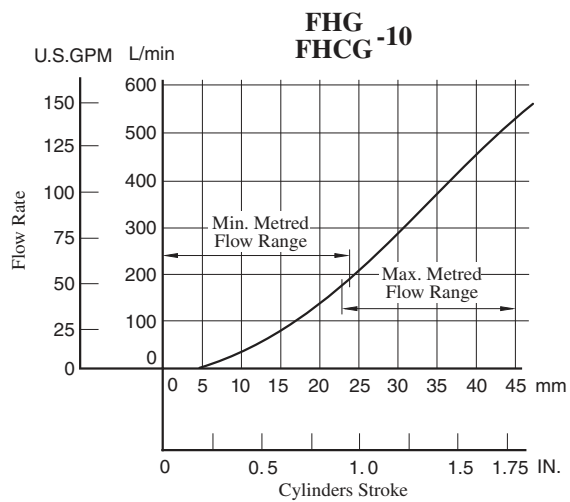
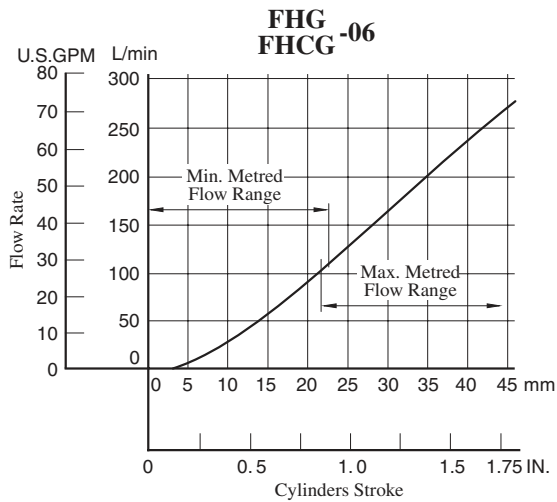
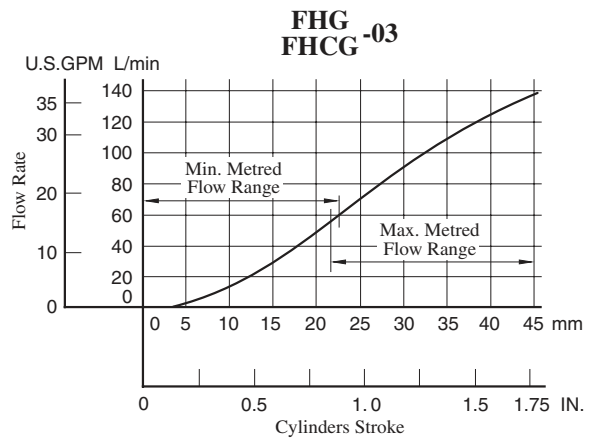
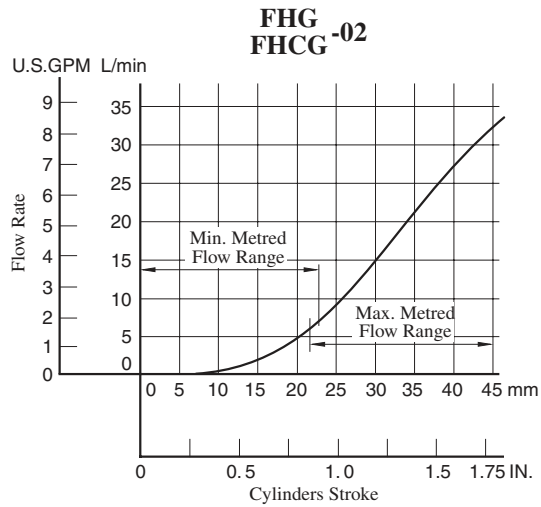

## Other Characteristics

The following characteristics are the same as for flow control valves;

- Metred Flow vs. Differential Pressure
- Metred Flow vs. Viscosity
- Min. Required Pressure Difference
- Pressure Drop for Reversed Free Flow (only for models with check valves)

See pages 284 to 286. For reference, the corresponding model No. of the flow control valves are shown below.

Valve Model No.	Model No.
FHG -02 FHCG	FG -02 FCG
FHG -03 FHCG	FG -03 FCG
FHG -06 FHCG	FG -06 FCG
FHG -10 FHCG	FG -10 FCG

D



Pilot Operated Flow Control Valves  
Pilot Operated Flow Control and Check Valves

● **Terminal Box Type**

FHG/FHCG-02-30-\*-\*\*-13/1390  
 FHG/FHCG-03-125-\*-\*\*-13/1390

Mounting surface:  
 FH\*G-02: ISO 6263-AK-06-2-A  
 FH\*G-03: ISO 6263-AM-07-2-A

**DIMENSIONS IN MILLIMETRES (INCHES)**

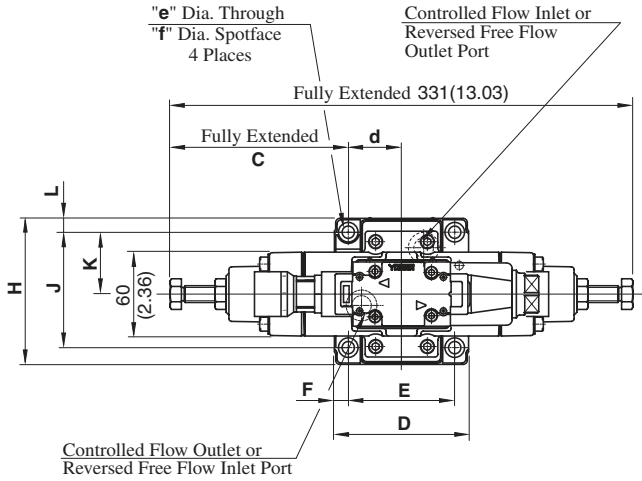

Model Numbers	n	t
FHG/FHCG-02-30-*-**-13	Rc 1/4	G 1/2
FHG/FHCG-02-30-*-**-1390	1/4 NPT	1/2 NPT
FHG/FHCG-03-125-*-**-13	Rc 1/4	G 1/2
FHG/FHCG-03-125-*-**-1390	1/4 NPT	1/2 NPT

Note: For dimensions of the valve mounting surface, see the installation drawing (P.281 and 282) of the sub-plate used together.

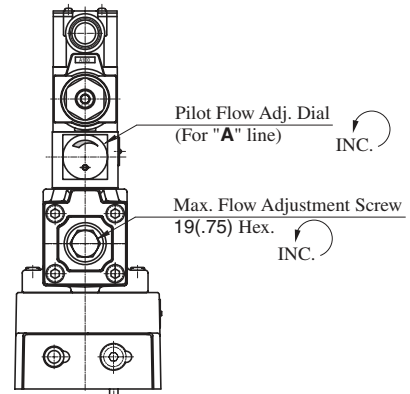
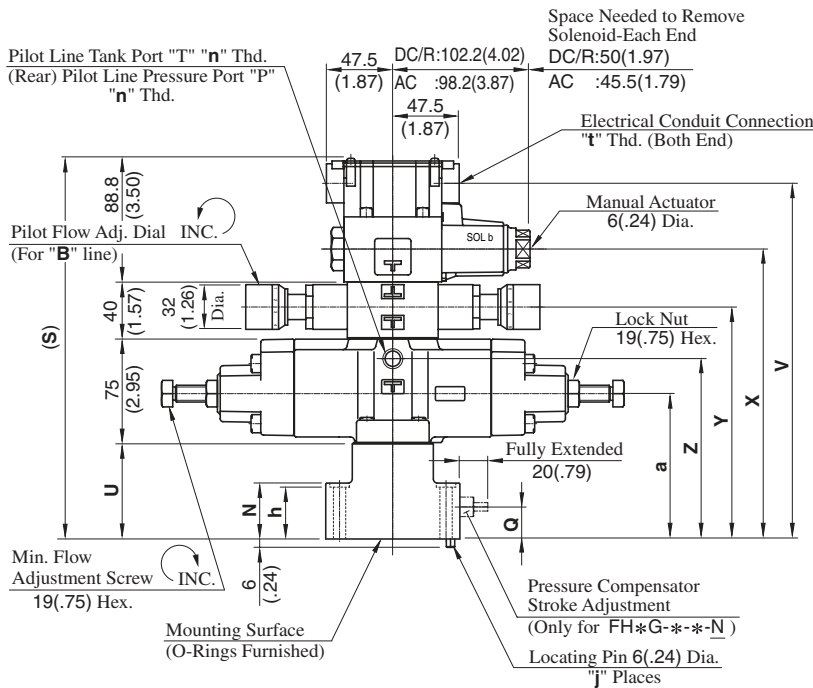

Model Numbers	Dimensions mm (Inches)															
	C	D	E	F	H	J	K	L	N	Q	S	U	V	X	Y	Z
FHG FHCG-02	127.4 (5.02)	96 (3.78)	76.2 (3.00)	9.9 (.39)	100.6 (3.96)	82.6 (3.25)	44.3 (1.74)	9 (.35)	40 (1.57)	23 (.91)	272.8 (10.74)	69 (2.72)	254.5 (10.02)	207.5 (8.17)	166 (6.54)	129 (5.08)
FHG FHCG-03	114.7 (4.52)	125 (4.92)	101.6 (4.00)	11.7 (.46)	125 (4.92)	101.6 (4.00)	61.8 (2.43)	11.7 (.46)	64 (2.52)	41 (1.61)	301.8 (11.88)	98 (3.86)	283.5 (11.16)	236.5 (9.31)	195 (7.68)	158 (6.22)

Model Numbers	Dimensions mm (Inches)					j
	a	d	e	f	h	
FHG FHCG-02	104 (4.09)	38.1 (1.50)	8.8 (.35)	14 (.55)	39 (1.54)	1
FHG FHCG-03	133 (5.24)	50.8 (2.00)	11 (.43)	17.5 (.69)	63 (2.48)	2

● Models with Plug-in Connector

FHG/FHCG-02-30-\*-N-13/1380/1390  
 FHG/FHCG-03-125-\*-N-13/1380/1390

DIMENSIONS IN  
 MILLIMETRES (INCHES)

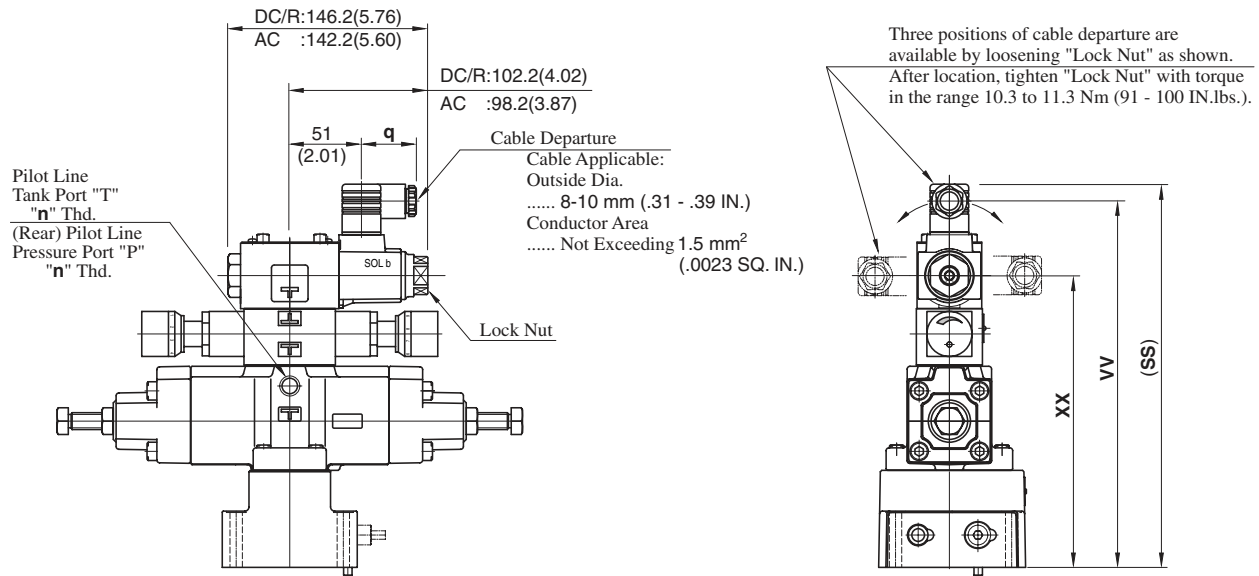

Model Numbers	Dimensions mm (Inches)				Remarks
	SS	VV	XX	q	
FHG/FHCG-02-30-*-A*-N	272.5 (10.73)	260.5 (10.26)	207.5 (8.17)	39 (1.54)	with AC Solenoid
FHG/FHCG-03-125-*-A*-N	301.5 (11.87)	289.5 (11.40)	236.5 (9.31)		
FHG/FHCG-02-30-*-D*-N	283.5 (11.16)	271.5 (10.69)	207.5 (8.17)	39 (1.54)	with DC Solenoid
FHG/FHCG-03-125-*-D*-N	312.5 (12.30)	300.5 (11.83)	236.5 (9.31)		
FHG/FHCG-02-30-*-R*-N	286.5 (11.28)	264.7 (10.42)	207.5 (8.17)	53 (2.09)	with AC → DC Solenoid
FHG/FHCG-03-125-*-R*-N	315.5 (12.42)	293.7 (11.56)	236.5 (9.31)		

Model Numbers	Thread Size		
	Japanese Std. "JIS" Design 13	European Design Std. Design 1380	N.American Design Std. Design 1390
	"n" Thd.	"n" Thd.	"n" Thd.
FHG/FHCG-02-30-*-N	Rc 1/4	1/4 BSP.F	1/4 NPT
FHG/FHCG-03-125-*-N			

● For other dimensions, refer to "Terminal Box Type".

D  
 Pilot Operated Flow Control Valves  
 Pilot Operated Flow Control and Check Valves

● **Terminal Box Type**

FHG/FHCG-06-250-\*-13/1390  
 FHG/FHCG-10-500-\*-13/1390

Mounting surface:  
 FH\*G-06: ISO 6263-AP-08-2-A

**DIMENSIONS IN  
 MILLIMETRES (INCHES)**

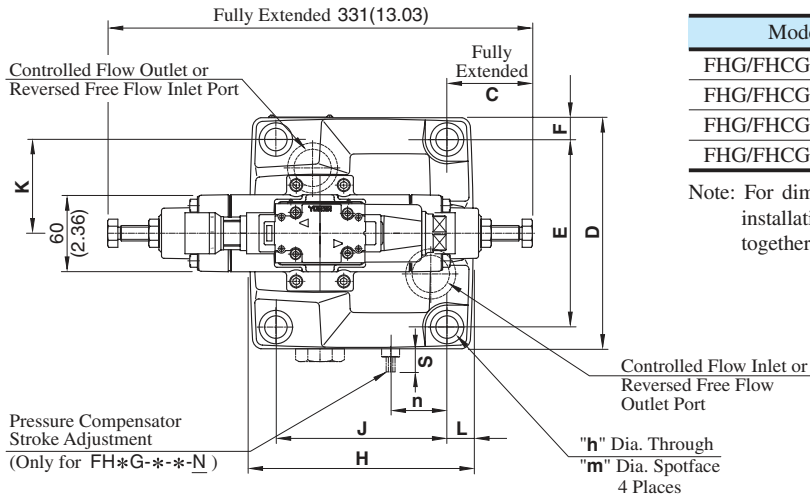

Model Numbers	q	r
FHG/FHCG-06-250-*-13	Rc 1/4	G 1/2
FHG/FHCG-06-250-*-1390	1/4 NPT	1/2 NPT
FHG/FHCG-10-500-*-13	Rc 1/4	G 1/2
FHG/FHCG-10-500-*-1390	1/4 NPT	1/2 NPT

Note: For dimensions of the valve mounting surface, see the installation drawing (P.282 and 283) of the sub-plate used together.

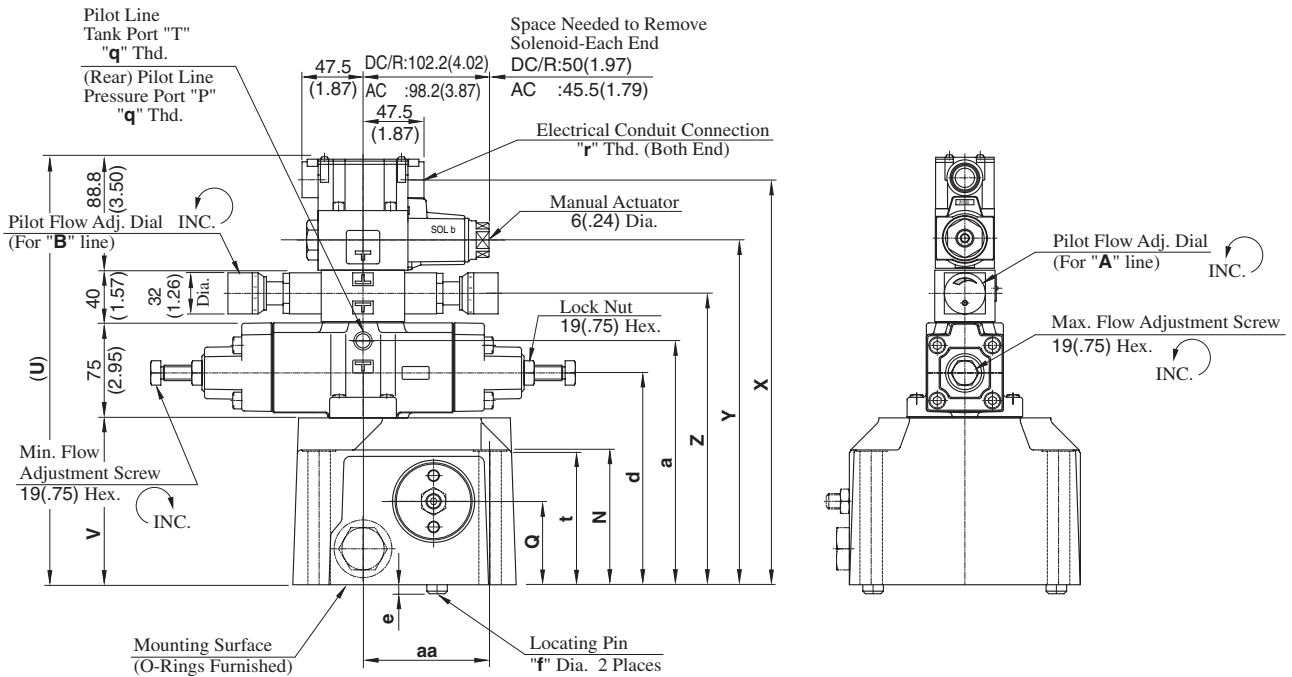

Model Numbers	Dimensions mm (Inches)															
	C	D	E	F	H	J	K	L	N	Q	S	U	V	X	Y	Z
FHG-06 FHCG-06	66.5 (2.62)	180 (7.09)	146.1 (5.75)	17 (.67)	174 (6.85)	133.4 (5.25)	73.1 (2.88)	20.3 (.80)	105 (4.13)	65 (2.56)	18 (.71)	333.8 (13.14)	130 (5.12)	315.5 (12.42)	268.5 (10.57)	227 (8.94)
FHG-10 FHCG-10	21 (.83)	244 (9.61)	196.9 (7.75)	23.5 (.93)	228 (8.98)	177.8 (7.00)	98.5 (3.88)	25.1 (.99)	137 (5.39)	85 (3.35)	23 (.91)	363.8 (14.32)	160 (6.30)	345.5 (13.60)	298.5 (11.75)	257 (10.12)

Model Numbers	Dimensions mm (Inches)								
	a	d	e	f	h	m	n	t	aa
FHG-06 FHCG-06	190 (7.48)	165 (6.50)	7 (.28)	16 (.63)	17.5 (.69)	26 (1.02)	44 (1.73)	103 (4.06)	99 (3.90)
FHG-10 FHCG-10	220 (8.66)	195 (7.68)	10 (.39)	18 (.71)	21.5 (.85)	32 (1.26)	61 (2.40)	135 (5.31)	144.5 (5.69)

● Models with Plug-in Connector

FHG/FHCG-06-250-\*-N-13/1380/1390  
 FHG/FHCG-10-500-\*-N-13/1380/1390

DIMENSIONS IN  
 MILLIMETRES (INCHES)

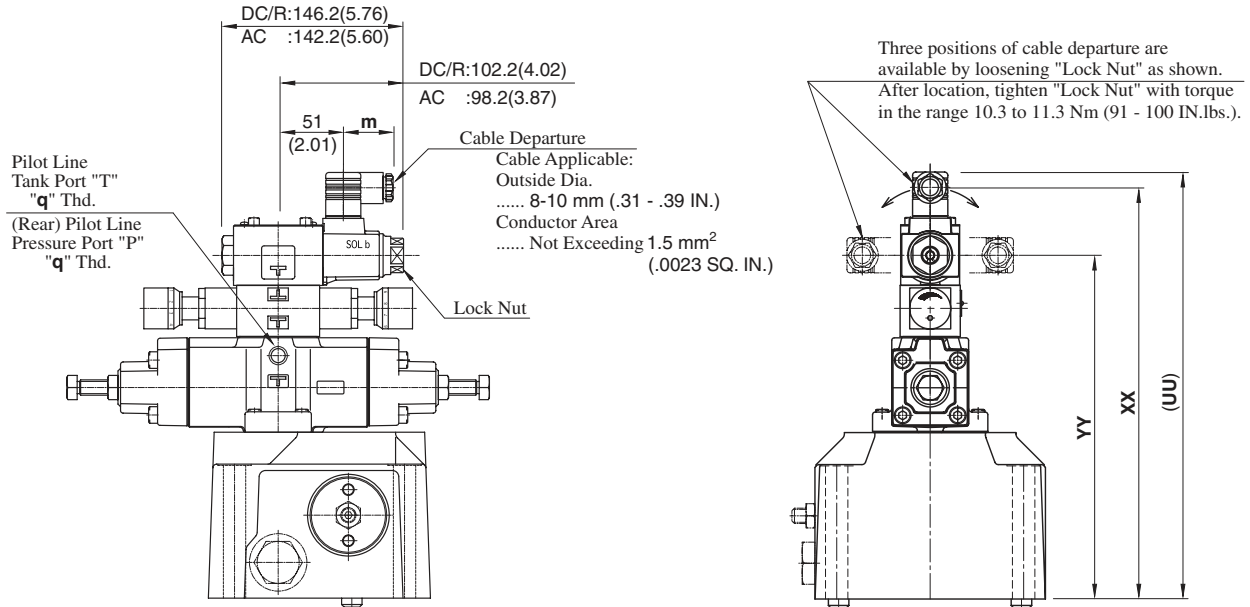

Model Numbers	Dimensions mm (Inches)				Remarks
	UU	XX	YY	m	
FHG/FHCG-06-250-*-A*-N	333.5 (13.13)	321.5 (12.66)	268.5 (10.57)	39 (1.54)	with AC Solenoid
FHG/FHCG-10-500-*-A*-N	363.5 (14.31)	351.5 (13.84)	298.5 (11.75)		
FHG/FHCG-06-250-*-D*-N	344.5 (13.56)	332.5 (13.09)	268.5 (10.57)	39 (1.54)	with DC Solenoid
FHG/FHCG-10-500-*-D*-N	374.5 (14.74)	362.5 (14.27)	298.5 (11.75)		
FHG/FHCG-06-250-*-R*-N	347.5 (13.68)	325.7 (12.82)	268.5 (10.57)	53 (2.09)	with AC → DC Solenoid
FHG/FHCG-10-500-*-R*-N	377.5 (14.86)	355.7 (14.00)	298.5 (11.75)		

Model Numbers	Thread Size		
	Japanese Std. "JIS" Design 13	European Design Std. Design 1380	N.American Design Std. Design 1390
	"q" Thd.	"q" Thd.	"q" Thd.
FHG/FHCG-06-250-*-N	Rc 1/4	1/4 BSPF	1/4 NPT
FHG/FHCG-10-500-*-N			

● For other dimensions, refer to "Terminal Box Type".

D  
 Pilot Operated Flow Control Valves  
 Pilot Operated Flow Control and Check Valves

■ List of seals

● Terminal Box Type

FHG/FHCG-02-30-\*-N-13/1390  
 FHG/FHCG-03-125-\*-N-13/1390

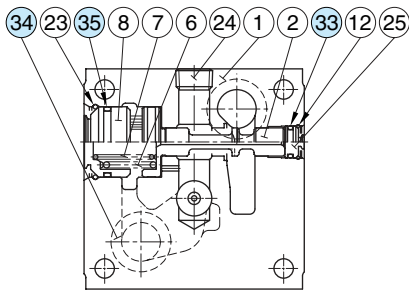
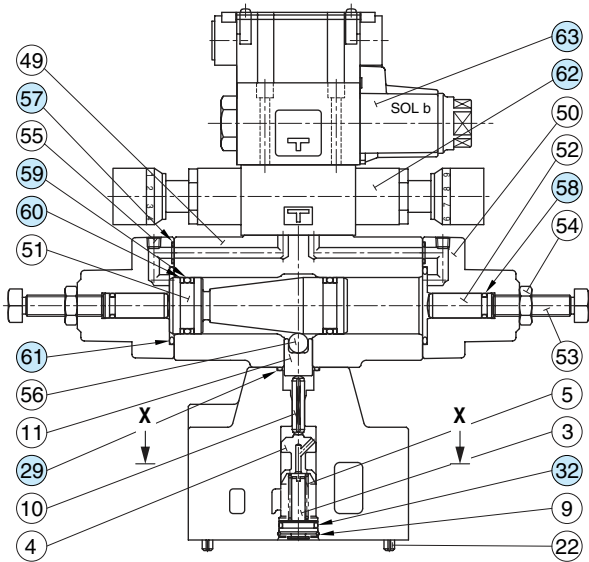

(FHG-\* Type)

● Models with Plug-in Connector

FHG/FHCG-02-30-\*-N-13/1380/1390  
 FHG/FHCG-03-125-\*-N-13/1380/1390

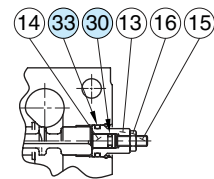
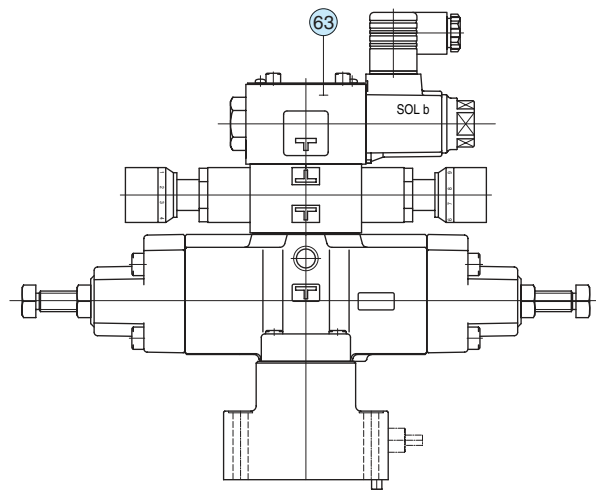

( FHG  
 FHCG -\*-N Type )

(FHCG-\* Type)

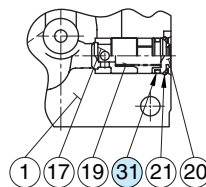

Section X-X

● List of Seals

Item	Name of Parts	Part Numbers		Qty.
		FHG -02 FHCG	FHG -03 FHCG	
29	O-Ring	SO-NB-P20	SO-NB-P20	1
30	O-Ring	SO-NB-P5	SO-NB-P5	1
31	O-Ring	SO-NB-P10A	SO-NB-P16	1
32	O-Ring	SO-NB-P12	SO-NB-P18	1
33	O-Ring	SO-NB-P14	SO-NB-P14	1
34	O-Ring	SO-NB-P18	SO-NB-P28	2
35	O-Ring	SO-NB-G25	SO-NB-G35	1
57	O-Ring	SO-NB-P9	SO-NB-P9	2
58	O-Ring	SO-NB-P10A	SO-NB-P10A	2
59	O-Ring	SO-NA-P26	SO-NA-P26	2
60	Back Up Ring	SO-BB-P26	SO-BB-P26	4
61	O-Ring	SO-NB-P38	SO-NB-P38	2

Note: When ordering the seals, please specify the seal kit number from the table right. In addition to the above seals, seals for pilot valves are included in the seal kit.

● Pilot Valves

See page 298 for the pilot valve model numbers to be used.

● List of Seal Kits

Valve Model Numbers	Seal Kit Numbers
FHG-02	KS-FHG-02-13
FHCG-02	KS-FHCG-02-13
FHG-03	KS-FHG-03-13
FHCG-03	KS-FHCG-03-13



● Terminal Box Type

FHG/FHCG-06-250-\*\*-\*\*-13/1390  
 FHG/FHCG-10-500-\*\*-\*\*-13/1390

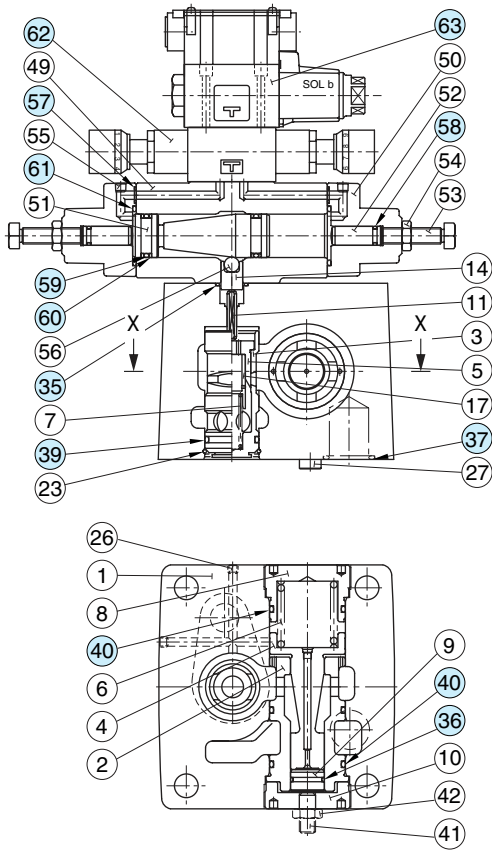

(FHG-\* Type)  
 Section X-X

● Models with Plug-in Connector

FHG/FHCG-06-250-\*\*-\*\*-N-13/1380/1390  
 FHG/FHCG-10-500-\*\*-\*\*-N-13/1380/1390

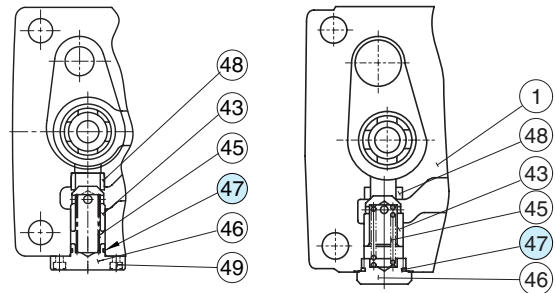
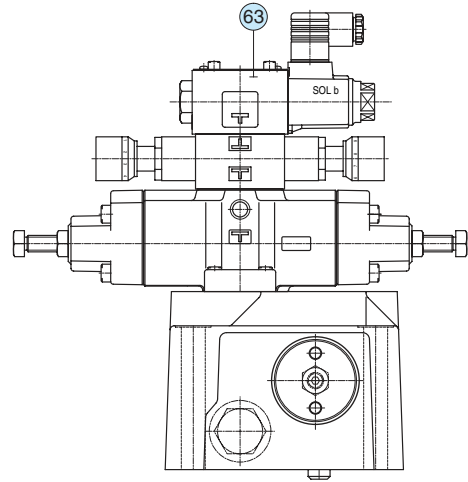

(FHCG-06 Type)

(FHCG-10 Type)

Section X-X

● List of Seals

Item	Name of Parts	Part Numbers		Qty.
		FHG FHCG-06	FHG FHCG-10	
35	O-Ring	SO-NB-P20	SO-NB-P20	1
36	O-Ring	SO-NB-P21	SO-NB-P34	1
37	O-Ring	SO-NB-P32	SO-NB-P48	2
39	O-Ring	SO-NB-P34	SO-NB-P50	1
40	O-Ring	SO-NB-P50	SO-NB-G75	3
47	O-Ring	SO-NB-A020	SO-NB-P32	1
57	O-Ring	SO-NB-P9	SO-NB-P9	2
58	O-Ring	SO-NB-P10A	SO-NB-P10A	2
59	O-Ring	SO-NA-P26	SO-NA-P26	2
60	Back Up Ring	SO-BB-P26	SO-BB-P26	4
61	O-Ring	SO-NB-P38	SO-NB-P38	2

Note: When ordering the seals, please specify the seal kit number from the table right. In addition to the above seals, seals for pilot valves are included in the seal kit.

● Pilot Valves

See page 298 for the pilot valve model numbers to be used.

● List of Seal Kits

Valve Model Numbers	Seal Kit Numbers
FHG-06	KS-FHG-06-13
FHCG-06	KS-FHCG-06-13
FHG-10	KS-FHG-10-13
FHCG-10	KS-FHCG-10-13

## List of Pilot Valves

### List of Pilot Valves

Type of Electrical Conduit Connections	Valve Model Numbers	Pilot Valve Model Numbers		Remarks
		Item No.62 Throttle and Check Modular Valves	Item No.63 Solenoid Operated Directional Valves	
Terminal Box Type	FHG/FHCG-02- 30-* -★ -13 FHG/FHCG-03-125-* -★ -13 FHG/FHCG-06-250-* -★ -13 FHG/FHCG-10-500-* -★ -13	MSW-01-X-50	DSG-01-2B2-★ -70	Japanese Std. "JIS"
	FHG/FHCG-02- 30-* -★ -1390 FHG/FHCG-03-125-* -★ -1390 FHG/FHCG-06-250-* -★ -1390 FHG/FHCG-10-500-* -★ -1390	MSW-01-X-50	DSG-01-2B2-★ -7090	N. American Design Std.
Plug-in Connector Type	FHG/FHCG-02- 30-* -★ -N-13 FHG/FHCG-03-125-* -★ -N-13 FHG/FHCG-06-250-* -★ -N-13 FHG/FHCG-10-500-* -★ -N-13	MSW-01-X-50	DSG-01-2B2-★ -N-70	Japanese Std. "JIS"
	FHG/FHCG-02- 30-* -★ -N-1380 FHG/FHCG-03-125-* -★ -N-1380 FHG/FHCG-06-250-* -★ -N-1380 FHG/FHCG-10-500-* -★ -N-1380	MSW-01-X-50	DSG-01-2B2-★ -N-70	European Design Std.
	FHG/FHCG-02- 30-* -★ -N-1390 FHG/FHCG-03-125-* -★ -N-1390 FHG/FHCG-06-250-* -★ -N-1390 FHG/FHCG-10-500-* -★ -N-1390	MSW-01-X-50	DSG-01-2B2-★ -N-7090	N. American Design Std.

Note: 1. Fill a coil type (a symbol representing current/voltage) in section marked ★ .  
 2. For the detail of the MSW-01 valve O-rings, see [Page 566](#).  
 3. For the detail of the DSG-01 valve O-rings, see [Page 359](#).